

# **PROGRAMMABLE DC SYSTEM**

**Operation and Maintenance Manual**

**MODEL AT8B-06-01-01-02-4354**

## **ELGAR ELECTRONICS CORPORATION**

9250 Brown Deer Road  
San Diego, CA 92121-2294  
1-800-73ELGAR (1-800-733-5427)  
Tel: (858) 450-0085  
Fax: (858) 458-0267  
Email: [sales@elgar.com](mailto:sales@elgar.com)  
[www.elgar.com](http://www.elgar.com)

©1997 by Elgar Electronics Corporation

This document contains information proprietary to Elgar Electronics Corporation. The information contained herein is not to be duplicated or transferred in any manner without prior written permission from Elgar Electronics Corporation.







## **ELGAR ONE-YEAR WARRANTY**

---

Elgar Electronics Corporation (hereinafter referred to as Elgar) warrants its products to be free from defects in material and workmanship. This warranty is effective for one year from the date of shipment of the product to the original purchaser. Liability of Elgar under this warranty shall exist provided that:

- the Buyer exposes the product to normal use and service and provides normal maintenance on the product;
- Elgar is promptly notified of defects by the Buyer and that notification occurs within the warranty period;
- the Buyer receives a Return Material Authorization (RMA) number from Elgar's Repair Department prior to the return of the product to Elgar for repair, phone 800-73-ELGAR (800-733-5427), ext. 2295;
- the Buyer returns the defective product in the original, or equivalent, shipping container;
- if, upon examination of such product by Elgar it is disclosed that, in fact, a defect in materials and/or workmanship does exist, that the defect in the product was not caused by improper conditions, misuse, or negligence; and,
- that Elgar QA seal and nameplates have not been altered or removed and the equipment has not been repaired or modified by anyone other than Elgar authorized personnel.

This warranty is exclusive and in lieu of all other warranties, expressed or implied, including, but not limited to, implied warranties of merchantability and fitness of the product to a particular purpose. Elgar, its agents, or representatives shall in no circumstance be liable for any direct, indirect, special, penal, or consequential loss or damage of any nature resulting from the malfunction of the product. Remedies under this warranty are expressly limited to repair or replacement of the product.

### **CONDITIONS OF WARRANTY**

- To return a defective product, contact an Elgar representative or the Elgar factory for an RMA number. Unauthorized returns will not be accepted and will be returned at the shipper's expense.
- For Elgar products found to be defective within thirty days of receipt by the original purchaser, Elgar will absorb all ground freight charges for the repair. Products found defective within the warranty period, but beyond the initial thirty-day period, should be returned prepaid to Elgar for repair. Elgar will repair the unit and return it by ground freight pre-paid.
- Normal warranty service is performed at Elgar during the weekday hours of 7:30 am to 4:30 pm Pacific time. Warranty repair work requested to be accomplished outside of normal working hours will be subject to Elgar non-warranty service rates.
- Warranty field service is available on an emergency basis. Travel expenses (travel time, per diem expense, and related air fare) are the responsibility of the Buyer. A Buyer purchase order is required by Elgar prior to scheduling.
- A returned product found, upon inspection by Elgar, to be in specification is subject to an inspection fee and applicable freight charges.
- Equipment purchased in the United States carries only a United States warranty for which repair must be accomplished at the Elgar factory.

***ELGAR***

*Committed to Quality...Striving for Excellence*



## SAFETY NOTICE

The Model AT8000B Programmable DC Power Supply is a state-of-the-art system. Configuration, test, operation or maintenance should only be performed by qualified personnel. The system is designed to be used only in a protected environment; it must be rack mounted or installed inside other equipment.

BEFORE APPLYING POWER to the System, verify that the Model AT8000B is properly configured for the user's particular application.

The Model AT8000B is factory wired for a nominal 115 VAC input voltage. Verify that the available AC input voltage is consistent with how the unit is wired.

### WARNING



*HAZARDOUS VOLTAGES IN EXCESS OF 115 VRMS, 200V PEAK MAY BE PRESENT WHEN COVERS ARE REMOVED. QUALIFIED PERSONNEL MUST USE EXTREME CAUTION WHEN SERVICING THIS EQUIPMENT. CIRCUIT BOARDS, TEST POINTS AND OUTPUT VOLTAGES MAY ALSO BE FLOATING ABOVE (BELOW) CHASSIS GROUND.*

Installation and servicing must be performed by QUALIFIED PERSONNEL who are aware of properly dealing with attendant hazards. This includes such simple tasks as fuse verification and channel reconfiguration.

Ensure that the AC power line ground is properly connected to the Model AT8000B input connector. Similarly, other power ground lines including those to application and maintenance equipment **MUST** be properly grounded for both personnel and equipment safety.

Always ensure that facility AC input power is de-energized prior to connecting or disconnecting the power cable. Similarly, the Model AT8000B circuit breaker must be switched OFF prior to connecting or disconnecting output power.

## SAFETY NOTICE (Continued)

In normal operation, the operator does not have access to hazardous voltages within the chassis. However, depending on the user's application configuration, **HIGH VOLTAGES HAZARDOUS TO HUMAN SAFETY** may be normally generated on the output terminals. The Customer/User must ensure that the output power (and sense) lines be properly labeled as to the SAFETY hazards and any that inadvertent contact with hazardous voltages is eliminated.

Guard against risks of electrical shock during open cover checks by **NOT TOUCHING** any portion of the electrical circuits. Even when power is OFF, capacitors may retain an electrical charge. Use **SAFETY GLASSES** during open cover checks to avoid personal injury by any sudden component failure.



	<u>Page</u>
Warranty .....	i
Safety Notice .....	ii
Table of Contents .....	iv

**SECTION I – GENERAL DESCRIPTION**

1.1	INTRODUCTION .....	1-1
1.2	GENERAL DESCRIPTION .....	1-1
1.3	OVERALL SYSTEM SPECIFICATIONS .....	1-2
	1.3.1 Electrical .....	1-2
	1.3.2 General Specifications .....	1-5
	1.3.3 Mechanical Specifications .....	1-6
	1.3.4 Programming Specifications .....	1-7
	1.3.5 Maintenance and Calibration .....	1-9
1.4	OUTPUT CONNECTOR DEFINITIONS .....	1-10
1.5	EN 61010-1 : 1993 .....	1-10

**SECTION II – INSTALLATION**

2.1	INTRODUCTION .....	2-1
2.2	UNPACKING .....	2-2
	2.2.1 Inspecting The Package .....	2-2
	2.2.2 Pre-Installation Inspection .....	2-2
2.3	INSTALLATION .....	2-3
	2.3.1 Dummy Modules .....	2-8
	2.3.2 DC Power Module Output Relays .....	2-8
2.4	CONFIGURATION .....	2-8
	2.4.1 System Configuration .....	2-8
	2.4.2 Emergency Shutdown Input .....	2-9
2.5	REAR PANEL SWITCHES AND CONNECTIONS .....	2-10
	2.5.1 Load Connections .....	2-10
	2.5.2 AC Input Power .....	2-11
	2.5.3 IEEE-488 Interface .....	2-12
	2.5.4 Channel Group Select .....	2-15
	2.5.5 DFI/Shutdown .....	2-16
	2.5.6 Output Connections .....	2-17

**SECTION III – OPERATION**

3.1	INTRODUCTION .....	3-1
3.2	POWER ON/OFF SEQUENCE .....	3-1
3.3	REMOTE PROGRAMMING OVERVIEW .....	3-2
3.4	REMOTE PROGRAMMING IN ABLE .....	3-3
3.4.1	Instrument Commands .....	3-4
3.4.1.1	CNF (Confidence Test) .....	3-4
3.4.1.2	RST (Reset Channels) .....	3-6
3.4.1.3	GRP (Group Channels) .....	3-6
3.4.1.4	PAR (Parallel Channels) .....	3-7
3.4.1.5	TST (Test Channels) .....	3-8
3.4.1.6	RTN (Return Channels) .....	3-9
3.4.1.7	PWRL .....	3-11
3.4.1.8	VER (Version of Instrument Firmware) .....	3-12
3.4.1.9	SCR Command to Fire Crowbar .....	3-12
3.4.1.10	NOX (No Execute) .....	3-13
3.4.1.11	GET (Group Exercise Trigger) .....	3-13
3.4.2	Channel Parameters .....	3-14
3.4.2.1	CH (Channel Number) .....	3-15
3.4.2.2	VOLT (Voltage) .....	3-15
3.4.2.3	CURL (Current Limit) .....	3-16
3.4.2.4	CURR (Constant Current) .....	3-16
3.4.2.5	CLS (Close) .....	3-17
3.4.2.6	OPN (Open) .....	3-17
3.4.2.7	SENS I (Sense Internal) .....	3-18
3.4.2.8	SENS X (Sense External) .....	3-18
3.4.2.9	DELAY (Time Delay) .....	3-19
3.4.3	Example Message Strings With ABLE .....	3-22
3.4.4	Service Request Status Bytes .....	3-23
3.5	IEEE-488 DEFINITIONS .....	3-24
3.5.1	ABLE Implementation of the GPIB .....	3-26

**SECTION IV – THEORY OF OPERATION**

4.1	BLOCK LEVEL DIAGRAM .....	4-1
4.2	PROCESSOR CONTROL .....	4-1
4.2.1	System Operation .....	4-1

Page

**SECTION V – PARTS LIST**

5.1 GENERAL ..... 5-1  
5.2 SPARE PARTS ORDERING ..... 5-1  
5.3 PARTS LISTS ..... 5-1

**SECTION VI – SCHEMATICS AND ASSEMBLY DRAWINGS**

6.1 GENERAL ..... 6-1  
6.2 DIAGRAMS ..... 6-1

**LIST OF APPENDIXES**

A WIRE GAUGE SELECTION ..... A-1  
B VERIFICATION CHECKSHEET ..... B-1

**LIST OF FIGURES**

2-1	Model AT8000B (Front and Side Views) .....	2-4
2-2	Model AT8000B (Rear View) .....	2-5
2-3	Model AT8000B MASTER Chassis Configuration Outline Drawing .....	2-6
2-4	Model AT8000B SLAVE Chassis Configuration Outline Drawing .....	2-7
2-5	Basic System Configuration .....	2-9
2-6	GPIB Address Switch (Rear Panel View) .....	2-13
2-7	Channel Group Select Switch (Rear Panel View) .....	2-16
3-1	Timing Diagram of Outputs for Approach #1 .....	3-20
3-2	Timing Diagram of Outputs for Approach #2 .....	3-21
4-1	AT8000B Block Level Diagram .....	4-3
4-2	Chassis Mainframe System Functional Block Diagram .....	4-4

**LIST OF TABLES**

1-1	Terminal Block Definitions .....	1-10
1-2	EN61010-1 : 1993 Symbols .....	1-11
2-1	GPIB Listen Address Settings .....	2-14
3-1	Service Request Messages .....	3-25
3-2	GPIB/Mnemonic Listing .....	3-26
3-3	ABLE Implemented Subsets on GPIB .....	3-27
5-1	AT8000B Parts Lists .....	5-1
6-1	AT8000B Diagram Listing .....	6-1

# **SECTION I**

## **GENERAL DESCRIPTION**



## **1.1 INTRODUCTION**

The Elgar Model AT8000B Programmable DC Power System provides the following attributes and capabilities:

- 6 Channels per Drawer.
- Expandable to 16 Channels.
- 4 VDC, 6 VDC and 12 VDC Modules.
- 592W per Single Drawer Output Power.
- Easily Reconfigurable V/I Application Ranges.
- IEEE-488 General Purpose Interface Bus (GPIB) Compatible.
- CE-97 Compliant.

## **1.2 GENERAL DESCRIPTION**

The Model AT8000B is a highly flexible precision DC power source designed to serve the challenges of Automatic Test Equipment (ATE) applications. The Model AT8000B incorporates a highly intelligent built in user interface with a wide range of available plug in DC Power Modules to meet the user's specific DC Power needs. The Model AT8000B simplifies and eliminates the complexities of combining individual DC power sources.

The Model AT8000B basic system is a compact rack mountable master chassis drawer. Remote programming is via the IEEE-488 GPIB using Elgar's ABLE (Atlas Based Language Extension). The Model AT8000B internal processor automatically keeps track of all remote programming, error reporting, BIT (Built In Test), and other processes.

The Model AT8000B master chassis contains six slots which are filled with DC Power Modules as required by the user's application. Each slot containing a master DC Power Module is an independently programmable channel DC power source. A built-in polarity relay enables both plus and minus ( $\pm$ ) programming without external wiring changes to the user's load. Excellent precision is always maintained via internal and external (programmable) voltage sensing.

Several Expansion drawers may be configured together for additional channels (the processor in the master chassis keeps track of everything) via the same GPIB cable and address. Expansion drawers do not have separate GPIB programming; the Model AT8000B simply refers to each DC Power Module as a different channel regardless of the number of modules or expansion drawers installed.

The master chassis processor supports up to 12 independent programmable channels with only the use of an extension cable between them. Additional chassis require the use of a junction box to extend the channels to 16 total.

## **1.3 OVERALL SYSTEM SPECIFICATIONS**

### **1.3.1 Electrical**

#### **Configuration**

This system consists of two master chassis. An interconnect cable is required to connect a master to Intel's interface card (see Figure 2-5).

#### **Output Voltage Range**

Also, for compliance voltage in Constant Current Mode.

Each DC Power Module has a single output voltage range, as follows:

- 0 to 4 VDC
- 0 to 6 VDC
- 0 to 20 VDC

#### **Output Current Range**

Each DC Power Module has a single output current range as follows:

- 0 to 4 VDC Module: 20.0 A maximum from 0 VDC to 4 VDC.
- 0 to 6 VDC Module: 16.0 A maximum from 6 VDC to 0 VDC.
- 0 to 12 VDC Module: 10.0 A maximum from 0 VDC to 12 VDC.



**Rated Output Power**

- 4V/20A Module: 80 Watts
- 6V/16A Module: 96 Watts.
- 12V/10A Module: 120 Watts

**Voltage Accuracy**

±(0.05% of full range voltage +0.05% of programmed voltage) at 25°C (77°F).

**Current Accuracy**

±(1% of full range current +0.05% of programmed current) at 25°C (77°F).

**Load Regulation (Voltage Mode)**

±0.01% of full range voltage as measured at sense point.

**Load Regulation (Constant Current Mode)**

±0.1% of rated current.

**Line Regulation (Voltage Mode)**

±0.01% for a ±10% line voltage change.

**Line Regulation (Constant Current Mode)**

±0.05% for a ±10% line voltage change.

**Maximum Ripple and Noise (Voltage Mode)**

RMS All Three Modules: 1.5 mV RMS from 20 Hz to 100 kHz.

Peak-to-Peak All Three Modules: 15 mV peak-to-peak from 20 Hz to 20 MHz.

**Maximum Ripple and Noise (Constant Current Mode)**

0.1% of maximum rated current from 20 Hz to 100 kHz; 2% peak to peak of maximum rated current from 20 Hz to 20 MHz.

**Readback Measurement Accuracy (TST Function)**

0.5% of full scale above 1% of full scale for voltage.

1% of full scale above 1% of full scale for current.

**Stability (After Warmup)**

±0.01% of rated output for 24 hours at constant temperature, line voltage and load conditions.

**Temperature Coefficient**

±0.01% per °C of rated output voltage in Voltage mode.

±0.025% per °C of rated output current in Constant Current mode.

**Response to Step Load Current**

Recovers to within ±0.1% of final value in 300  $\mu$ sec with a 10% step in load current.

**Channel to Channel Interaction**

Does not exceed specified performance limits of a single module.

**Nominal Input Line Voltage**

115 VAC, factory wired.

**Input Voltage Range**

±10% of nominal value.

**Input Frequency Range**

47 Hz to 63 Hz

**Overvoltage Protection**

Auto-tracking with automatic shutdown at 110% of programmed output voltage for programmed voltages from 10% to 100% of range. In Constant Current mode, OVP tracks to 110% of programmed compliance voltage.

**Overcurrent Protection**

Auto-tracking with automatic shutdown at 110% of programmed output current for programmed output currents from 10% to 100% of range.

**Input Circuit Breaker**

Front panel mounted 20A two-pole circuit breaker provides overcurrent protection and is the ON/OFF power switch. The AC line cord must be disconnected from the power source to completely remove AC voltage from the chassis assembly.

**Fault Detection**

Continuously monitors overvoltage, overcurrent, module malfunction and over-temperature conditions. Includes immediate shutdown and reporting. Built In Test includes the Confidence Test. A built-in Test Board allows remote test/monitoring.

**1.3.2 General Specifications****Operating Temperature Range (Up to 2000 Feet)**

0°C to 50°C (32°F to 122°F).

**Operating Temperature Range (Up to 6000 Feet)**

0°C to 35°C (32°F to 95°F).

**Storage Temperature Range**

-40°C to 75°C (40°F to 167°F).

**Storage Altitude**

0 to 50,000 feet.

**MTBF**

10,000 hours with six DC Power Modules operating at rated power output and ambient air inlet temperature of 25°C (77°F).

**Warmup**

30 minutes maximum in a 25°C (77°F) environment.

**Life Expectancy**

5 years minimum.

**Humidity**

0 to 95% non-condensing.

**Shock**

The chassis assembly has been designed to meet the requirements for shipment and bench handling of electrical equipment and instruments.

**Vibration**

The unit will meet the requirements of IEC 68-2-6. Vibration conditions are: 0.15mm amplitude; frequency of 10-55-10 Hz; sweep rate of 1 octave/minute, vertical axis only for 30 minutes.

**Efficiency**

50% to 60% at full rated output power at nominal AC input voltage, depending upon module voltage.

**Insulation Resistance and Dielectric Withstanding Voltage**

10 MΩ at 400 VDC at 25°C and <50% relative humidity.

**1.3.3 Mechanical Specifications****Size**

19" (483mm) wide by 5 1/4" (133mm) high by 23" (584mm) deep for mounting in a standard RETMA rack (refer to Figures 2-1 and 2-2).

**Net Weight**

Approximately 80 pounds (36kg) with six power modules.

**Finish**

Light gray, color number 26408, per FED STD 595 with black silkscreen, color 27038.

**Handles**

Front panel mounted lifting handles.

**Material**

Steel chassis with aluminum front panel.

**Cooling**

Forced air with three internal cooling fans.

**Input Power Connection**

Three wire plug type NEMA 5–20P (115 VAC, 20 A) with six-foot power cord hardwired to chassis.

**Output Power Connection**

Separate four wire output terminal block per DC Power Module.

**Remote Programming Connector**

Standard IEEE–488 GPIB female connector.

**Remote Chassis Connector**

Parallel connection via rear panel-mounted 37-pin sub-miniature D type connector. Extender chassis interconnects via Elgar P/N 5970138–01 cable on J8.

**1.3.4 Programming Specifications****Interface**

IEEE 488–1978 GPIB (General Purpose Interface Bus) interface standard including subsets SH1, AH1, T6, L4, SR1, RL1, and DC1.

**GPIB Address**

Set by rear panel DIP switch.

**Number of Channels**

Up to 16 at a single GPIB address.

**Modes of Operation**

Voltage Mode: Programmable output voltage with programmable upper current limit.

Constant Current Mode: Programmable output current with programmable compliance voltage limit.

**Voltage Programming Range**

4, 6 and 12 VDC Modules: 0 to full scale voltage. Zero to full scale current.

**Maximum Resolution**

1.2 mV and 10 mA for 4 VDC modules.

10 mV and 10 mA for 12 VDC modules.

**Module Identification**

DC Power Module voltage range, current characteristics and options are stored an internal PROM, located on the DC module. The contents of the PROM are read by the processor each time power is turned on.

**SPECIFICATIONS ARE SUBJECT TO CHANGE  
WITHOUT NOTICE**

### 1.3.5 Maintenance and Calibration

**WARNING**

*Hazardous voltages are present when the unit is operating or when the cover is removed. Qualified personnel must use extreme caution when operating or servicing this equipment.*

The only periodic maintenance required is cleaning and removal of all dust and dirt from the intake and exhaust areas which could impede normal airflow patterns.

The cooling fans should be inspected for proper rotation and cleanliness.

Questions regarding the repair and servicing of this equipment should be directed to the nearest Elgar representative or to the Service Department of Elgar Corporation, 9250 Brown Deer Road, San Diego, California 92121. **Do not return a chassis assembly or DC power module without prior authorization.**

The unit has been inspected, tested and calibrated prior to shipment. Thus, calibration by the customer is not normally required.

There are fuses in the chassis assembly and the DC power modules. The fuses are not accessible from the outside of the assembly. A blown fuse is a possible indication of a more serious component failure or condition. Thus, fuse replacement by the customer is **not** recommended.

## 1.4 OUTPUT CONNECTOR DEFINITIONS

The output connector for DC supplies on the rear of the chassis are defined in Table 1-1. This definition only applies when the reverse polarity relay is not being used. When using reverse polarity, all positive and negative terminals are reversed.

**Table 1-1. Terminal Block Definitions**

Terminal Block	Definition
Top Terminal	Positive Output Power
Second to Top Terminal	Positive Voltage Sense
Third to Top Terminal	Negative Voltage Sense
Bottom Terminal	Negative Output Power

## 1.5 EN 61010-1 : 1993

Table 1-2 provides the symbols to be used in the Model AT8000B.

### NOTE



*Items Number 12 and 14 in Table 1-2 have the following colors: Background color - yellow; symbol and outline - black.*

### NOTE



*Color requirements for symbols 12 and 14 do not apply to markings on equipment, providing that the symbol is molded or engraved to a depth or raised height of 0.5 mm. The symbol should be sufficiently large to ensure that it will be noticed when necessary.*



Table 1-2. EN 61010-1 : 1993 Symbols

Number	Symbol	Publication	Description
1		IEC 417, No. 5031	Direct Current
2		IEC 417, No. 5032	Alternating Current
3		IEC 417, No. 5033	Both Direct and Alternating Current
4	3	IEC 617-2, No. 02-02-06	Three-Phase Alternating Current
5		IEC 417, No. 5017	Earth (Ground) Terminal
6		IEC 417, No. 5019	Protective Conductor Terminal
7		IEC 417, No. 5020	Frame or Chassis Terminal
8		IEC 417, No. 5021	Equipotentiality
9		IEC 417, No. 5007	On (Supply)
10		IEC 417, No. 5006	Off (Supply)
11		IEC 417, No. 5172	Equipment protected throughout by DOUBLE INSULATION or REINFORCED INSULATION (equivalent to Class II of IEC 536)
12 (See Notes above)		ISO 3864, No. B.3.6	Caution, risk of electric shock
13	Symbol under consideration		Easily-touched higher temperature parts
14 (See Notes above)		ISO 3864, No. B.3.1	Caution (refer to accompanying documents)

**Notes**

## **SECTION II**

# **INSTALLATION**



## 2.1 INTRODUCTION

The Model AT8000B is configured, calibrated, and tested prior to shipment. Therefore, this instrument is ready for immediate use upon receipt. The following initial physical inspections should be made to ensure that no damage has been sustained during shipment.

### WARNING



*Hazardous voltages are present when operating this equipment. Read the "SAFETY" notices on page ii prior to performing installation, operation, or maintenance.*

### CAUTION



*Do NOT apply AC input voltage to this instrument nor connect any load(s) without first verifying correct input line voltage and output wiring configuration. This instrument and any external loads or cables may be damaged by improper voltage settings, mixing modules of different channels, cable mis-wiring, etc.*

The following topics and verification of the user's particular configuration are necessary prior to connecting cables and applying AC input power.

To simplify this process, the topics are arranged as follows:

- 2.2 Unpacking
- 2.3 Installation
- 2.4 Configuration
- 2.5 Rear Panel Switches and Connections

Appendix A contains information on Wire Gauge Selection. Appendix B contains the Configuration and Functional Verification Checksheet (photocopy and use this checksheet as required). The Checksheet simplifies the user's Model AT8000B configuration and functional verification process. It also serves as an ideal reference during application hookup and as a permanent maintenance record.

## **2.2 UNPACKING**

### **2.2.1 Inspecting The Package**

Inspect the shipping container before accepting the container from the carrier. If damage to the container is evident, remove the instrument from the container and visually inspect it for damage to the instrument case and parts.

If damage to the instrument is evident, a description of the damage should be noted on the carrier's receipt and signed by the driver or carrier agent. Save all shipping containers and material for inspection.

Forward a report of any damage to the Elgar Service Department, 9250 Brown Deer Road, San Diego, CA 92121. Elgar will provide instructions for repair or replacement of the instrument.

Retain the original packing container should subsequent repacking for return to the factory be required. Repacking is straightforward and is essentially the reverse of unpacking. Should only a subassembly need to be repackaged for re-shipment, use the original containers. Elgar will provide shipping instructions and containers, if necessary.

### **2.2.2 Pre-Installation Inspection**

Inspect the instrument and associated modules (if any were shipped separately) for shipping damage such as dents, scratches, or distortion.

Remove the modules from their shipping containers and inspect each one for damage. There is no need to remove any module already installed in any chassis drawer unless damage is suspected.

Check the rear of the instrument for damage to the connectors.

Check the ID label on the chassis assembly top cover and/or the DC Power Modules. Verify that the correct material has been received. The label should contain all input and output voltage, current and power requirements. The label should comply with International standards (refer to Table 1-5).

## 2.3 INSTALLATION

The Model AT8000B is 5.25" (133.35mm) high and is designed to be installed in a standard 19" (483mm) rack cabinet. The instrument chassis is pre-drilled for rack slide mounting. Rack slides are recommended for periodic maintenance since all normal adjustments are accessible via the instrument top cover. Rack slides are available from Elgar.

### CAUTION



*When rack mounting the AT8000B, DO NOT use screws that protrude into the chassis of the AT8000B more than 0.30" (7.6mm). Longer screws will short internal components to the chassis, causing the AT8000B to malfunction.*

### CAUTION



*Avoid blocking instrument air intakes or exhaust.*

Both instrument air intakes are located on the sides near the chassis front. Exhaust is past the heat sinks to the whole rear panel. Avoid blocking these intakes and exhaust. No special vertical separation is required when stacking instruments. However, a 1.75" (44.45mm) vertical space above and below the instrument is required. Figure 2-1 depicts the location of air intakes, air exhaust, and rack mounting; Figure 2-2 provides the location of the rear panel switches and connectors; and Figures 2-3 and 2-4 provide outline drawings for the AT8000B.

Should the user's Model AT8000B have one or more expansion chassis drawers, the user will want to verify or set the Channel Group Select Switch located on the rear of the respective chassis. The master chassis processor supports 16 channels no matter how many extension drawers are used. Each channel assignment is determined by the placement of a master module. Slots 1 through 6 correspond to channels 1 through 6, respectively, when the Channel Group Select Switch is set to position "A".

To obtain channel assignments 7 through 12, merely set the corresponding Group Select Switch to position "B". Similarly, position "C" corresponds to channels 13 through 16.

(CHASSIS - FRONT VIEW)

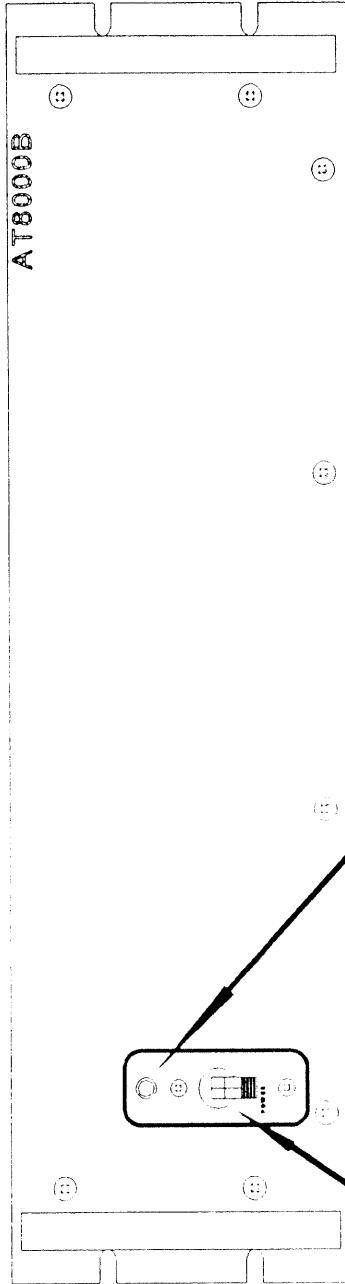

POWER ON  
INDICATOR  
(DS1)

INPUT POWER  
CIRCUIT BREAKER  
(CB1)

AIR INTAKE VENTS  
(BOTH SIDES AND TOP COVER)

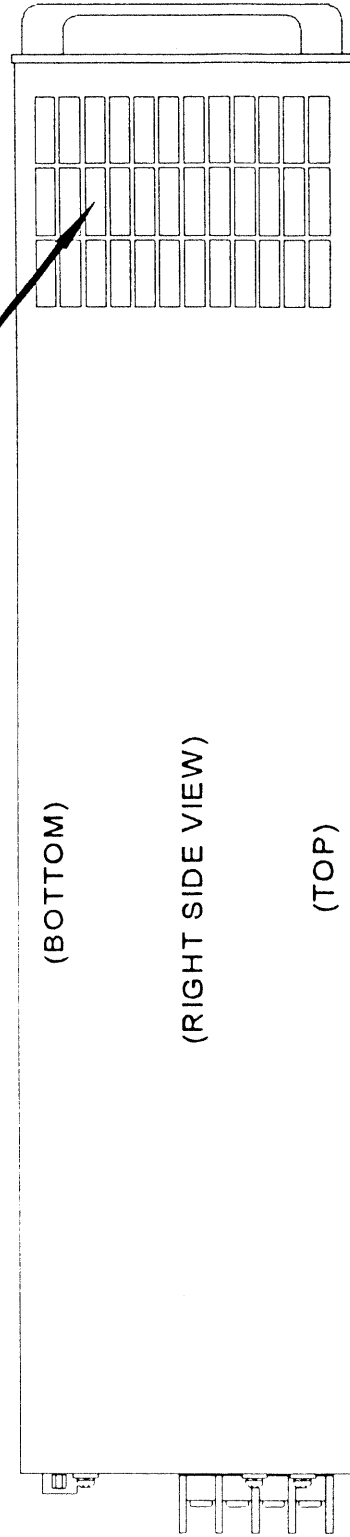
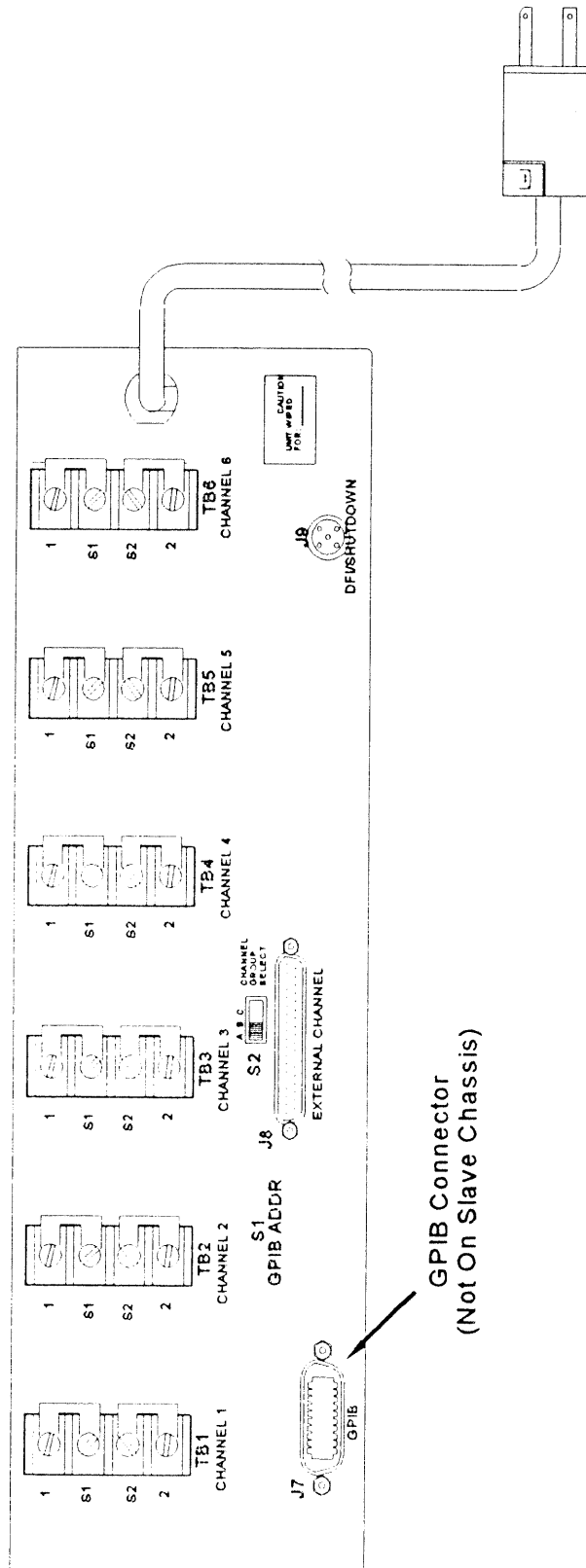

Figure 2-1. Model A T8000B (Front and Side Views)





GPIB Connector  
(Not On Slave Chassis)

Figure 2-2. Model AT8000B (Rear View)

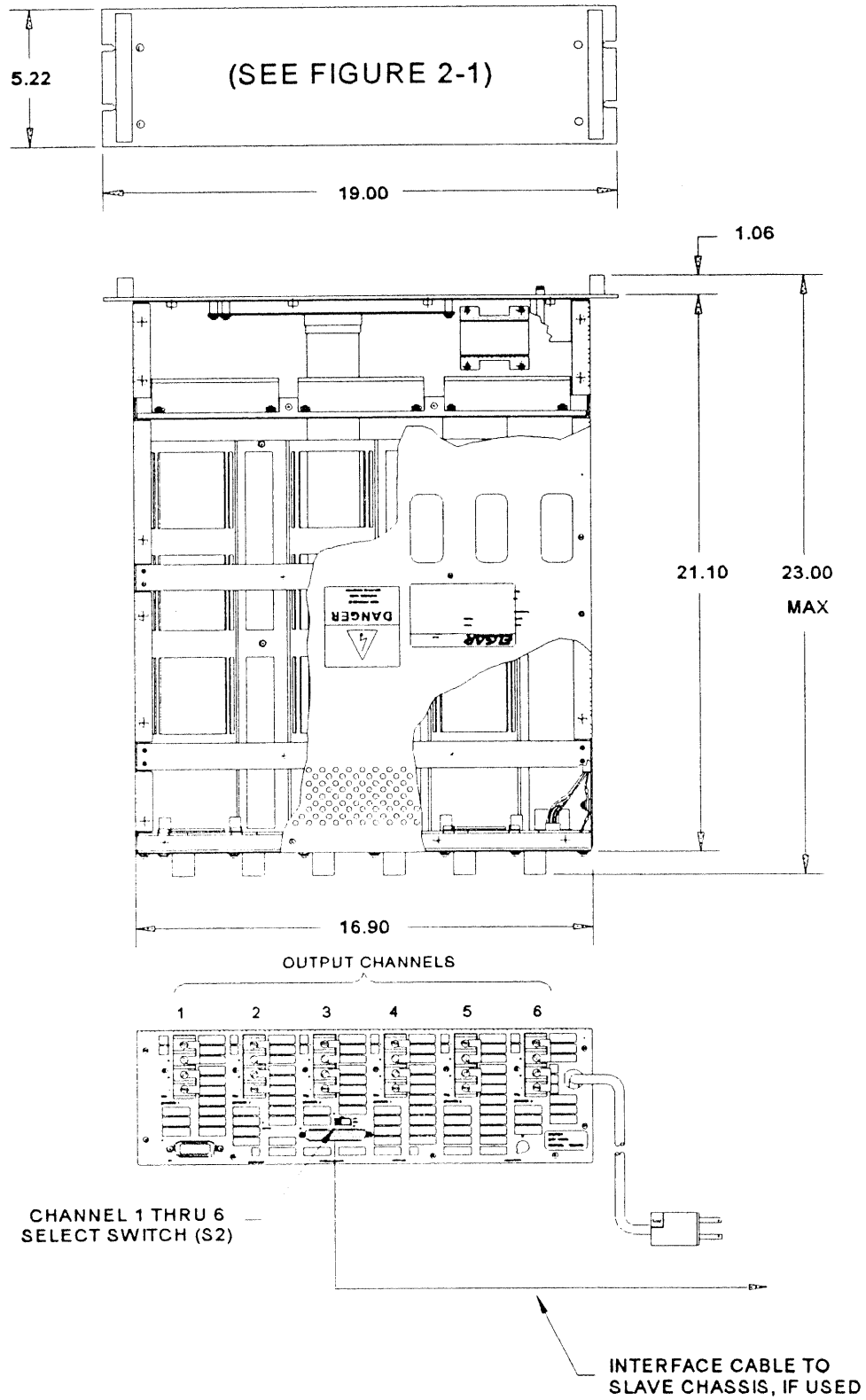

Figure 2-3. Model AT8000B MASTER Chassis Configuration Outline Drawing

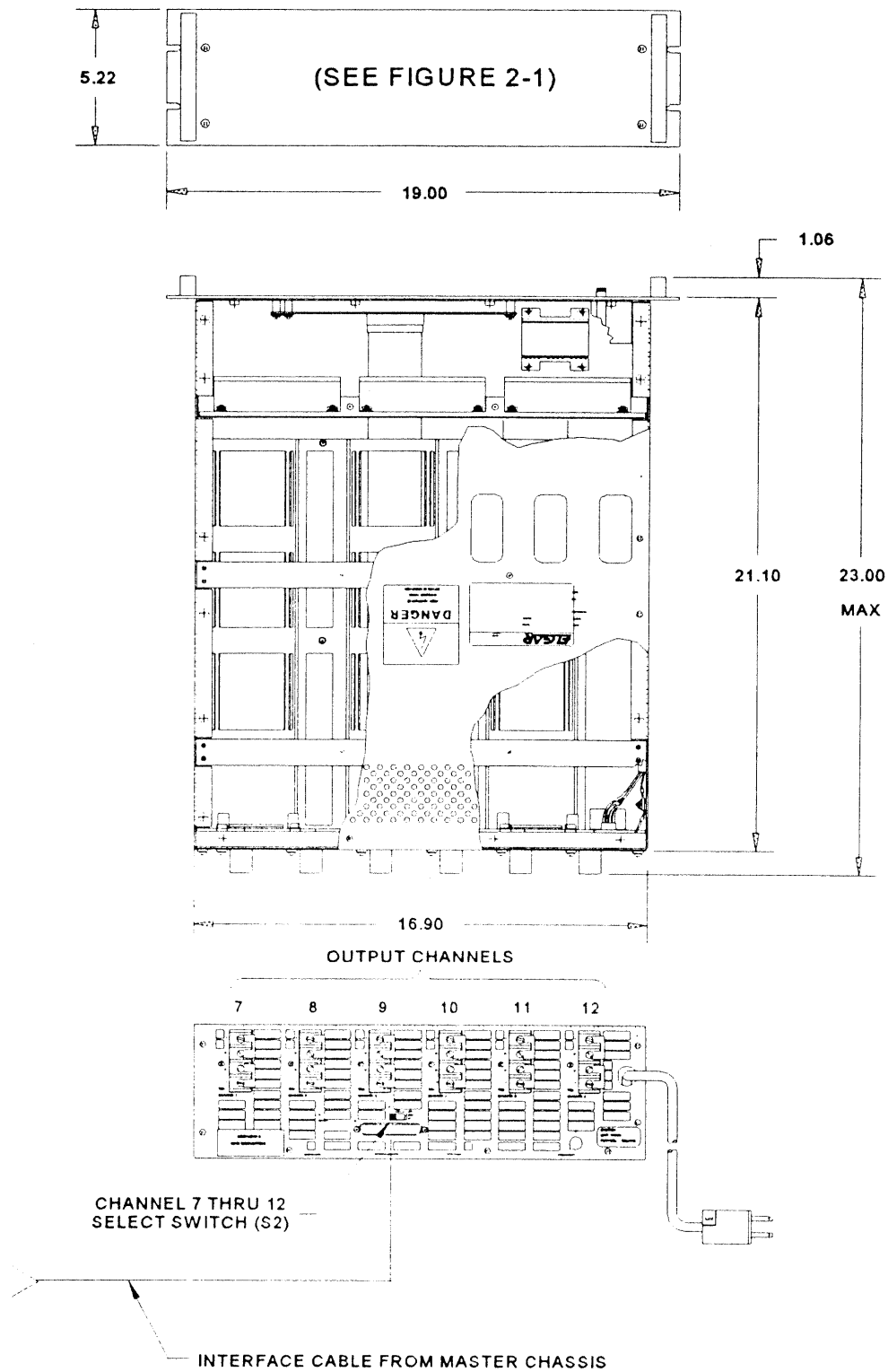

Figure 2-4. Model AT8000B SLAVE Chassis Configuration Outline Drawing

### **2.3.1 Dummy Modules**

A dummy module consists of a vertical board configured as an air flow restrictor. The module plugs into the chassis bottom slot and fits into the top brackets as any other module, except that the module has no electrical connections.

Dummy modules are installed when a chassis is not otherwise fully loaded with six DC Power Modules. Dummy modules redirect forced cooling air towards the real DC Power Module heat sinks and not through the empty space of the chassis.

### **2.3.2 DC Power Module Output Relays**

Each DC Power Module has three sets of output relays: sense, isolation, and polarity. These relays are remotely programmable. They also automatically respond to fault conditions.

The sense relay selects either external or internal voltage sensing for channel voltage regulation and Test (monitoring).

The output isolation relay connects or removes (isolates) the DC Power Module output from the User Load.

The reverse polarity relay inverts the output voltage (and sense polarity) upon command. This provides both plus and minus polarity to a user load.

## **2.4 CONFIGURATION**

The Model AT8000B System may be factory or field configured to meet any ATE requirement. The Model AT8000B includes a processor, BIT (Built In Test) capability, a remote programming interface via GPIB, and up to six DC power channels – all within a single 5.25" (133.35mm) rack-mountable chassis.

### **2.4.1 System Configuration**

The AT8000B system suffix number –4354 consists of 2 chassis containing 6 channels each (refer to Figure 2-5). Both chassis have the same configuration, but one of them will be set for operation (S2 in Position "B") with Channels 7-12.

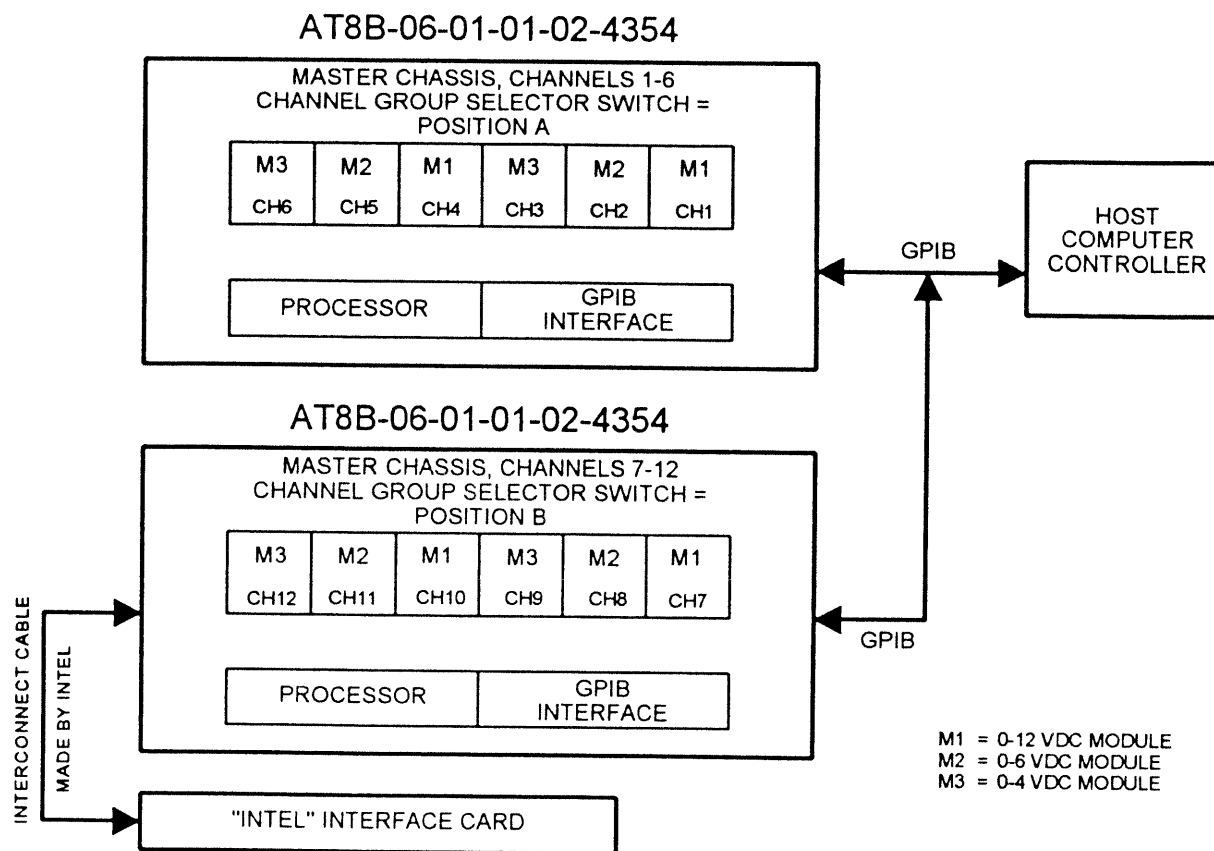

Figure 2-5. Basic System Configuration

### 2.4.2 Emergency Shutdown Input

This feature provides the capability of shutting down the entire AT8000B system by means of an externally driven signal.

All channels are programmed to zero volts, zero current and all the relays are opened (same as power up quiescent conditions) when the input pins (DFI pins D and E) are shorted together. This can be initiated by the controller or by a manual button.

These pins should be shorted by isolated relay contacts so the AT8000B is not connected electrically to noise or external voltages. One of the pins is the processor board digital ground and the other is the +5V power pin pulled up through a 33 kΩ resistor. By shorting the two signals, the processor reads the normally high pulled up signal as a logic zero and immediately initiates the shut down sequence.

## 2.5 REAR PANEL SWITCHES AND CONNECTIONS

### 2.5.1 Load Connections

Each Model AT8000B DC Power Module has its own output power and voltage sense terminals. These connections are on the chassis rear on a slot-by-slot basis.

As shown in Figure 2-2, the optional polarity relay automatically switches the output voltage and sense leads whenever a minus polarity is programmed. Rear panel positive/negative signals are then internally reversed.

#### Terminal Block (Standard, No Reverse Polarity Enabled)

<u>Terminal</u>	<u>Definition</u>
Top-most	Positive Output (1)
2nd from top	Positive External Sense (S1)
3rd from top	Negative External Sense (S2)
Bottom-most	Negative Output (2)

#### CAUTION



*THE MAXIMUM VOLTAGE BETWEEN ANY CHANNELS OR THE CHASSIS MUST BE LIMITED TO 80 VOLTS. Should the user's application require additional float capability, consult the factory.*

Selection of output power and sense line cabling should follow good practice specific to the application. An output cable should be able to carry the full output load current and maximum voltage under worst case conditions of temperature, humidity, mechanical abuse, and effects of long term aging. The sense cable has comparable requirements, but the sense current requires a smaller wire gauge. Sense line shielding from stray pickup is more rigorous. General guidelines for designing/specifying these cables are included in Appendix A.

If sense lines are not externally connected, the Model AT8000B individual channels still regulate output voltage due to internal voltage sense sampling within the master module(s). However, as output current load increases, a channel's internal sense sample is not able to accurately correct for possible IR losses within the output power cable. Also, the internal sense point is before the output relays; thus, load regulation is approximately 20mv per ampere of load current. External voltage sensing at the User load is always preferred, when possible, to cancel the adverse effects of cable losses.

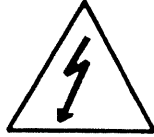
**WARNING**

*The Model AT8000B is capable of generating high voltages at its output terminals under normal conditions. The installer MUST ensure that all cables, sense resistors, bypass capacitors, User Load Terminal strips/connectors, etc. are all properly labeled as to the HAZARDS TO HUMAN SAFETY, as applicable.*

### 2.5.2 AC Input Power

The Model AT8000B is operated from nominal 115 VAC power lines. From the factory, the unit should already be configured for the user's local AC line voltage.

The AC input line ground wire provides safety ground for the instrument chassis.

Standard connector version is a six foot long AC input power cable hardwired into the rear of the chassis. The other end of the power cable is a three terminal twenty ampere male connector labeled NEMA 5-20 (or NEMA 5-20P). This appears very similar to the household NEMA 5-15 (115 VAC, 15 ampere) plug, except one pin is turned 90° to indicate its 20 ampere rating. Each chassis has its own separate AC power cable.

Mating receptacle is a NEMA 5-20R (115 VAC, 20 ampere) receptacle, which accepts both 15 and 20 ampere NEMA plugs.

### 2.5.3 IEEE-488 Interface

Remote programming uses the standard 24-pin female IEEE-488 (GPIB – General Purpose Interface Bus) connector on the rear of the master chassis drawer. No additional GPIB cable is installed to the extender chassis(s) since the master chassis processor communicates from master chassis to each extender chassis via its own 37-pin connector cable(s). GPIB cables are available from Elgar.

Adjacent to the GPIB connector, as depicted in Figure 2-2, is an internally mounted rear panel 5-bit DIP switch. This is the GPIB listen address switch. From the factory, this is set to decimal address 17, as shown in Figure 2-6, but it may be readily changed by the User.

**CAUTION**

*Since both master chassis are shipped with their GPIB address set to 17, one chassis needs to be changed in order to not have a bus problem.*

The DIP switch GPIB address is valid for Model AT8000B remote programming regardless of the number of channels installed.

The GPIB address DIP switch may be set to any address from 0 through 30, as per Figure 2-6. An UP or ON is interpreted as a logical 1 by the internal processor. AC power must be recycled after changing this DIP switch since it is read only once, during power up.

Remote programming via the GPIB is covered in Section III.

Table 2-1 identifies switch setting for various addresses.



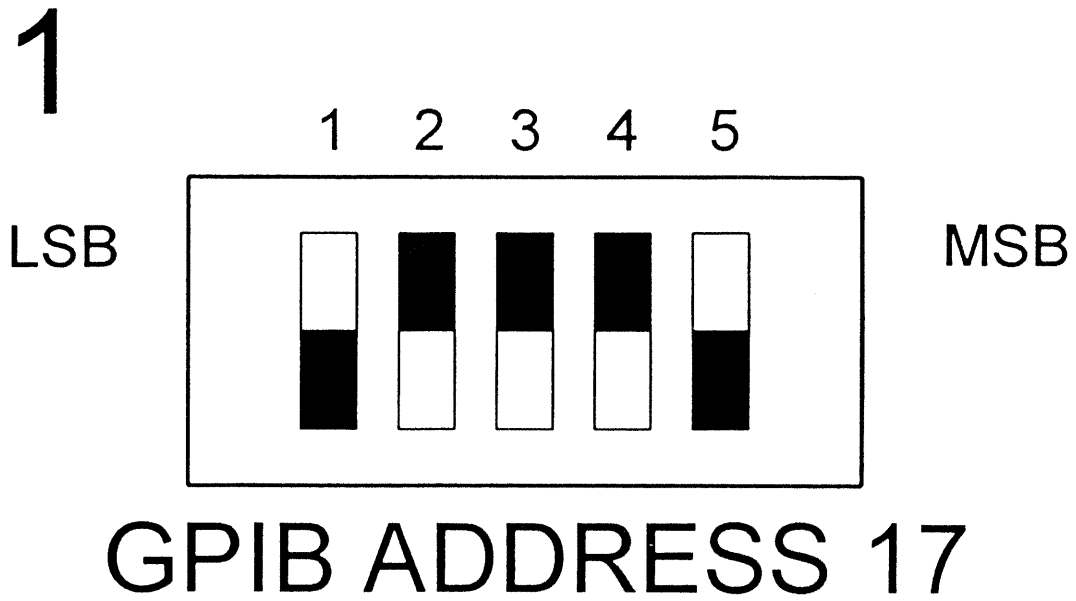

Figure 2-6. GPIB Address Switch (Rear Panel View)

Table 2-1. GPIB Listen Address Settings

ASCII CHARACTER	GPIB LISTEN ADDR						
	HEX	DEC	1	2	3	4	5
<SP>	00	0	0	0	0	0	0
!	01	1	1	0	0	0	0
"	02	2	0	1	0	0	0
#	03	3	1	1	0	0	0
\$	04	4	0	0	1	0	0
%	05	5	1	0	1	0	0
&	06	6	0	1	1	0	0
'	07	7	1	1	1	0	0
(	08	8	0	0	0	1	0
)	09	9	1	0	0	1	0
*	0A	10	0	1	0	1	0
+	0B	11	1	1	0	1	0
,	0C	12	0	0	1	1	0
-	0D	13	1	0	1	1	0
.	0E	14	0	1	1	1	0
/	0F	15	1	1	1	1	0
0	10	16	0	0	0	0	1
* 1	11	17	1	0	0	0	1
2	12	18	0	1	0	0	1
3	13	19	1	1	0	0	1
4	14	20	0	0	1	0	1
5	15	21	1	0	1	0	1
6	16	22	0	1	1	0	1
7	17	23	1	1	1	0	1
8	18	24	0	0	0	1	1
9	19	25	1	0	0	1	1
:	1A	26	0	1	0	1	1
;	1B	27	1	1	0	1	1
<	1C	28	0	0	1	1	1
=	1D	29	1	0	1	1	1
>	1E	30	0	1	1	1	1

\* - Factory Setting

### 2.5.4 Channel Group Select (Channel Group Select Switch)

Each chassis drawer contains six slots and, thus, up to six independent channels. Additional chassis drawers may be expanded onto the master chassis for additional slots of channels, as explained in Section 2.4, Configuration.

The Channel Group Select Switch (S2) permits slots of a given chassis drawer to be assigned different ranges of channel addresses. The master chassis processor supports 16 channels maximum.

The Channel Group Select Switch (S2) is located on the rear panel as seen in Figure 2–7. The switch position determines which of the three channel ranges are to be assigned to master modules contained within its respective chassis drawer. More than one chassis drawer may share the same switch setting provided that master modules are not installed in identical slots as described in the Configuration topic. Slots 1 through 6 are left to right as viewed from the rear panel.

Channel Group Switch S2 assignments are:

#### **Position A**

A master module in the left–most slot becomes channel number 1 (rear panel view). Sequentially, counting slots to the right, each slot receives the next channel assignment. Slot 2 is assigned channel 2, slot 3 is assigned channel 3, etc. The right–most slot is assigned channel 6.

#### **Position B**

Similar to Position A except channel assignment range is from channel 7 (slot 1 left–most) to channel 12 (slot 6 right–most).

#### **Position C**

Similar to Position A except channel assignment is from channel 13 (slot 1 –left–most) up to channel 16 (slot 4). The two right–most slots may not be used by master modules. They may remain empty or may be used as slave modules to one or more master modules located in the same chassis in slots 1 through 4.

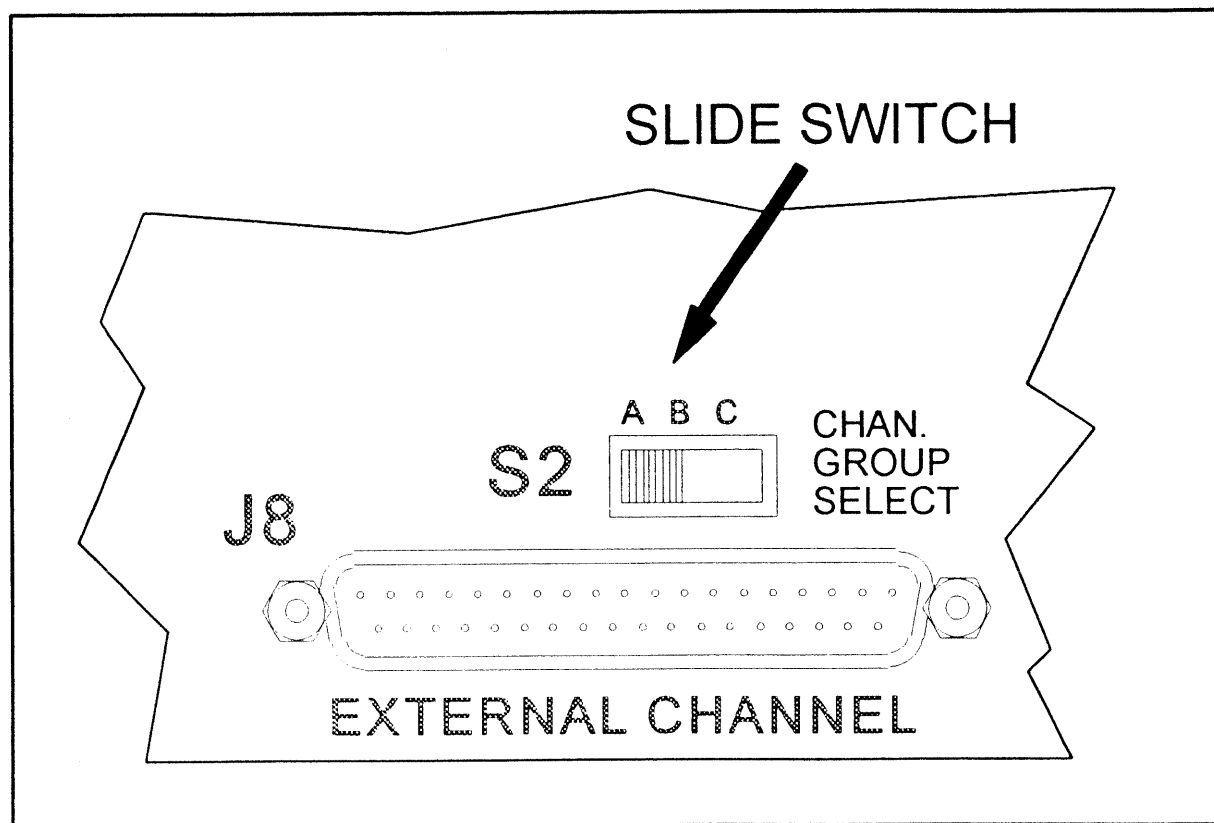

Figure 2-7. Channel Group Select Switch (Rear Panel View)

### 2.5.5 DFI/Shutdown

For military applications using the CIIL language, both DFI (Direct Fault Indicator) and Shutdown are included on the same master chassis rear panel connector, J9.

In this ABLE language version, Shutdown is available; there is no DFI.

Shutdown provides the Operator/ Programmer/Controller with the means to immediately reset the Model AT8000B without waiting for the GPIB. Shutdown uses the two pins with an internal isolated soft +5 volts. Momentarily closing the circuit across these two pins via an external relay contact or switch (only) immediately initiates the processor to open all channel relays and reset all setups to zeros (instrument reset routine).

**CAUTION**

*DO NOT ATTEMPT TO GROUND EITHER OF THESE PINS, since this causes a ground loop which may be potentially destructive to the instrument Processor board.*

DFI/Shutdown connector J9 (Amphenol 126–218), if installed, is located on the master chassis rear panel. The User supplied mating connector is Amphenol 126–217. The connector pin assignments are:

Pin Description

A	DFI relay contact (not used)
B	DFI relay contact (not used)
C	--
D	Shutdown
E	Shutdown

**2.5.6 Output Connections**

Output connections should be terminal type connectors.

## Notes

**SECTION III**

**OPERATION**





### 3.1 INTRODUCTION

The Model AT8000B System controls are straightforward and readily understood after just a brief overview. Similarly, remote programming via the ABLE (Atlas Based Language Extension) ATE language is quick and simple since the Model AT8000B processor transparently takes care of the burdens of protocol, parsing, message format, error checks, and talker response messages back to the host ATE controller.

The Model AT8000B does not accept any self-destructive setup. However, care must be taken since the wide range output of this instrument can generate voltages at sufficient current to cause great harm to equipment loads.

Operation of the Model AT8000B is organized into the following topics:

- 3.2 Power On/Off Sequence
- 3.3 Remote Programming Overview
- 3.4 Remote Programming in ABLE
- 3.5 IEEE-488 Definitions

#### WARNING



*VOLTAGES HAZARDOUS TO HUMAN SAFETY may be routinely generated at the output terminals. Be familiar with the SAFETY notices on page ii. Use great care when any load is connected to the output of this instrument. The user MUST notify any operator or technician via WARNING signs or labels as to the possible hazards of voltage and current.*

### 3.2 POWER ON/OFF SEQUENCE

Perform the following:

1. Verify the proper Installation of the user's Model AT8000B, including AC line voltage, any chassis drawer interconnects, and output/ sense connections.
2. Switch Power to ON for all Model AT8000B master chassis. It is also normal to switch AC POWER ON to the user's entire system from a central circuit breaker.

3. Immediately upon power on of the master chassis, the master chassis processor performs housekeeping on itself and the rest of the system. An initial one-time scan during this housekeeping identifies and records all installed channels, regardless of their chassis drawer(s).
4. The processor then resets all output power modules to open circuit, clears all programming information, and initializes the GPIB interface. Subsequently, the processor continuously performs internal housekeeping and scans for keyboard and remote programming inputs.
5. To Power OFF, good practice encourages disconnecting module outputs prior to removing AC power. Conveniently, the Confidence Test automatically performs this task on all module outputs. This virtually eliminates unpredictable power down output glitches and hot switching of the isolation relays which can result in damaged contacts.

### 3.3 REMOTE PROGRAMMING OVERVIEW

Should output isolation or polarity relays require a change of state, the processor automatically first turns off (voltage and current to zero) the particular channel(s). Relays are then switched and, after a 30 ms delay, all module voltages and currents are re-programmed simultaneously to their previous levels. This automatic sequence eliminates hot relay switching and possible voltage spikes due to contact bounce as seen by the load.

In the ABLE language, all channels are independent. Should a run-time fault on one channel occur, the other channels are not affected unless specifically programmed via the GRP (Group) command. GRP is valuable when multiple DC power channel sets (or groups) are required for the user's application and all the DC power supply channels shut down in the event of a fault on any one supply in the set.

Remote programming faults are signaled to the controller via GPIB talk messages from the Model AT8000B processor.

Syntax Notation used in this section is as follows:

Capital letters are required for remote command words and front panel keys.

- [ ] Square brackets indicate optional programming. Text within square brackets is not required.
- < > Angle brackets contain text which defines what it should be replaced by.
- | Vertical bars separate multiple choices of entries available. At least one of the entries must be chosen unless the entries are also enclosed within square brackets.
- ... Ellipses indicate an entry may be repeated as needed.

### 3.4 REMOTE PROGRAMMING IN ABLE

The ABLE (Atlas Based Language Extension) via GPIB provides the Programmer with a flexible format for numerical entry. Channel numbers do not require the leading zeros. Other numeric entries use free format defined in the syntax that follows. The polarity of voltage entered automatically determines the state of the polarity relay.

Programming strings sent via the GPIB to the Model AT8000B must be terminated with either a carriage return line feed (hex 0D 0A) and or line feed (hex 0A) and or the GPIB EOI. Talk strings sent from the Model AT8000B are terminated with the universally accepted carriage return line feed (hex 0D 0A) and EOI.

Two types of programming instructions are sent to the Model AT8000B: commands and channel setup parameters. Commands prepare or fetch information related to the channels on a System level. Channel setup parameters are the specific voltage, current, and relay positions desired on the individual channels.

Syntax applicable to remote ABLE programming is:

**<channel>**: A one or two digit numeric entry for the channel number. A leading zero is not required for single digit channel numbers. When programming channel numbers, "S" indicates all installed channels. When "S" is used, all installed channels are programmed to the same specified values. This is useful on systems with only modules of the same voltage where programming time is a concern. In this manner, all channels, up to 16, can be programmed in approximately the same amount of time it takes to program one channel.

**<value>**: A numeric entry in free format. No leading zeros are required; however, a single **<space>** is required between the parameter and the first number in the value. Consists of up to six digits plus optional decimal (.) plus an exponent. May be preceded by optional plus sign (+). A negative sign (-) for voltage implements the Polarity relay (if installed). No embedded **<spaces>** nor commas. The exponent is upper case "E" followed by an optional plus (+) or minus (-) sign followed by one or two digits.

### 3.4.1 Instrument Commands

Instrument commands are GPIB remote programming instructions which reset the channels, fetch specific information concerning the channels, or configure mutual interaction between (among) channels and, thus, the instrument system. These particular commands do not generate any DC power supply output nor set up any individual channel parameters. Instead, these commands aid in the organization or re-organization of channels. In addition, these commands permit the Programmer/ remote ATE controller to look at which type of modules are installed, how they are programmed, and what is occurring within the instrument. The following instrument programming commands are not preceded by any CH (channel) assignments. A command is sent by itself in a programming string. It may not be combined with any other command nor any channel parameters (discussed in the following topic). Note the use of **<space>** in the following syntax.

#### 3.4.1.1 CNF (Confidence Test)

Syntax:

**CNF**

Example:

**CNF**

Perform Confidence Test.

CNF initiates the Confidence Test to execute on all channels. All relays are opened and, upon completion, all channels are reset to zero. Group and Parallel assignments are reset to sixteen independent channels. CNF cancels any RTN or TST.

The Confidence Test performs four separate tests to verify the readiness accuracy of the Model AT8000B DC Power Modules and its own Built In Test function. Test board option A3 must be installed for the last two of these tests. The output isolation relays are opened for the Confidence Test and, afterward, all channel setups are automatically reset to zeros.

The Confidence Test sequence runs Test #1 on all installed channels, starting with the highest channel number and then stepping down through each of the installed channels. If successful, Test #2 is next run on all channels, and so forth through Test #4. Should any channel fail, the Confidence Test continues with the same test # until all of the channels are tested or a second failure is detected. A second failure immediately stops the Confidence Test. Should any failure occur, the Test # does not advance.

**Test #1 – Crowbar Fire Test:** The processor sequentially addresses each channel and fires its crowbar, waits 30 ms, and reads the channel to ensure that its crowbar was activated.

**Test #2 – Current Limit Test:** The processor sequentially programs each module to 96.22% of full scale voltage and 0.5% of full scale current, waits 5 ms and reads the channel to ensure it is in the constant current (CURR) mode and that its current limit fail circuitry has been activated.

**Test #3 – Test Board Calibration TEST:** This test reads the reference voltage of the Built in Test (BIT) board A3 and verifies it to be within  $\pm 1.13\%$  of the actual voltage. Channels are not stepped since only the Test board is used. This test takes approximately 7 ms.

**Test #4 – Voltage Accuracy Test:** The processor sequentially programs each module to 80.56% of full scale voltage and 80.56% full scale current, waits 10 ms, and reads it to be within  $\pm 1.61\%$  of the programmed value. The reading takes approximately 7 ms.

Following these tests, all modules are programmed to zero, all relays remain open, and the front panel displays channel 01.

If only one channel fails a particular Confidence Test invoked from the remote controller, the processor generates an SRQ (numbers 221 through 236).

If more than one channel fails the Confidence Test invoked from the remote controller, the processor generates the SRQ number 237.

### 3.4.1.2 RST (Reset Channels)

Syntax:

**RST <channel>[[, <channel>]...]**

or

**RST S**

Examples:

**RST 4**

Reset channel 4.

**RST 1,3**

Reset channels 1 and 3.

**RST S**

Reset all installed channels.

RST initiates a reset routine on the specified channels. An "S" specifies all channels. RST simultaneously opens the specified channel relay, programs these channels to zeros, and releases these channels from any group or parallel assignments.

### **MRST**

When modules have been programmed into a PAR set (refer to 3.4.1.4), the command **MRST** must be used to reset the parallel (PAR) grouped modules.

### 3.4.1.3 GRP (Group Channels)

Syntax:

**GRP <channel> [[,<channel>]...]**

or

**GRP S**

Examples:

**GRP 1,2,3**

Place channels 1, 2, and 3 into a group.

**GRP 4,5**

Place channels 4 and 5 into another group.

**GRP 1,12**

Remove channel 1 from the above group and form a new group of channels 1 and 12.

**GRP S**

Group all channels into one set. Cancel all of the above group assignments.

GRP specifies which channels are to be combined into a set. "S" specifies all channels. Should any run-time failure occur on any channel within this set, all channels within the set are shut down simultaneously to protect the external load circuit and the associated DC Power Modules. Multiple GRP sets may be specified active at the same time.

When any channel is assigned via GRP, that channel's assignment to any other GRP is automatically removed. GRP must be used with the PAR command (see paragraph 3.4.1.4).

RST cancels all GRP assignments into 16 independent channels. Should any run-time failure occur on any channel within a GRP set, all channels within that set are reset and that GRP assignment is canceled.

**3.4.1.4     PAR (Parallel Channels)**

Syntax:

**PAR <channel> [[,channel>]...]**

or

**PAR S**

Examples:

**PAR 1,2,3**

Place channels 1, 2, and 3 into a PAR set.

**PAR 2,6**

Place channels 2 and 6 into a PAR set.

**PAR S**

All channels into one parallel set.

PAR specifies to the processor which sets of channels have their outputs connected in parallel for the benefit of additional output current. "S" specifies all installed channels. PAR does not refer to master/slave modules, but rather individual channels whose outputs are paralleled.

Without the PAR command, should high current levels be drawn, normally one of the channels would reach its programmed upper current value and initiate a protective shut down via the internal processor. This further initiates a Crowbar, drawing tremendous current from the other channels in parallel and quickly defeats the purpose of multiple outputs connected in parallel.

With the PAR command, all of the channels within a particular PAR set are allowed to reach their maximum programmed current before the processor initiates any protective shutdown and signal a fault. The maximum current is equal to the sum of the installed parallel channels.

PAR is canceled upon any failure within the set via the RST or MRST command.

Output isolation relays must close and open at precisely the same time by sending the CLS and OPN commands on the same programming line. Since channel outputs are connected together, if any channel's output is activated before a second channel, the second channel will see a voltage that is higher than its own value and consequently immediately Crowbar – possibly causing damage to the module.

### IMPORTANT

1. The PAR command must be used with the GRP command to ensure that any shut down simultaneously includes all channels within the PAR set.
2. Only modules of equal voltages can operate with the PAR command.

#### **3.4.1.5 TST (Test Channels)**

Syntax:

**TST <channel> [[,<channel>]...]**

or

**TST S**

Examples:

**TST 1**

Test channel 1.

**TST 1,2**

Test channels 1 and 2.



**TST S**

Test all installed channels.

TST initiates the Model AT8000B processor and BIT (Built In Test) to measure the actual voltage and current on the specified channel(s). "S" specifies all installed channels. Measurements are made at the sense terminals (internal or external, as setup) for voltage and across an internal current path resistor. The Model AT8000B processor signals completion of the measurements and formation of the Test measurement string by setting the instrument SRQ status byte (79 decimal).

To receive the measurement string, the controller sends the GPIB talk address of the Model AT8000B and, in turn, sets itself (controller) to its own GPIB listen address.

If the GPIB talk address has been sent to the Model AT8000B prior to completion of the measurement, the SRQ status byte (decimal 79) is not sent (be sure to DIMENSION the controllers string variable large enough to contain the entire returned TST string message.

TST is canceled by CNF and RST.

The Model AT8000B returns the TST measurements via the GPIB in the following format:

**TST: CHnn=PXX.XXV XX.XXA S R [,CHnn...]**

Where:

**nn** = channel number 16 down to 01 (as installed)  
**P** = + or – for the state of the polarity relay  
**X** = decimal number 0 through 9  
**V** = Volts  
**A** = A or C for CURL or CURR respectively  
**S** = I or X for Sense relay Internal or External  
**R** = C or O for output isolation relay closed or open  
**,** = separator between channels.

### 3.4.1.6 RTN (Return Channels)

Syntax:

**RTN<channel> [[,<channel>]...]**

or

**RTN S**

Example:

**RTN 1**

Form a setup string for channel 1.

**RTN 4,6**

Form setup strings for channels 4 and 6.

**RTN S**

Form a setup string for all channels.

RTN initiates the Model AT8000B to assemble a string containing programming setup for each of the specified channels. "S" specifies all installed channels.

To actually send the string, the Model AT8000B must be sent its talker address via the GPIB.

The returned string format is:

**RTN: CHnn= PXX.XXV XX.XXA S R[,CHnn...]**

Where:

- nn** = channel numbers 16 down to 01 (as installed)
- P** = + or – for the state of the polarity relay
- X** = decimal number 0 through 9
- V** = Volts
- A** = A or C for CURL or CURR respectively
- S** = I or X for Sense relay Internal or External
- R** = C or O for output isolation relay closed or open
- ,** = separator between channels.

### 3.4.1.7 PWRL

Syntax:

**PWRL<channel> [[,<channel>]...]**

or

**PWRL S**

Examples:

**PWRL 4**

Form an identity string for channel 4.

**PWRL 2,4**

Form identity strings for channels 2 and 4.

**PWRL S**

Form an identity string for all channels.

PWRL initiates the Model AT8000B to assemble a string identifying the power limits and installed options on each of the specified channel(s). "S" specifies all installed channels. To actually send the string, the Model AT8000B must be sent its talker address via the GPIB.

The returned Power Limit string format is:

**PWRL: CHnn=PXX.XXV XX.XA S R[,<CHnn...]**

Where:

**nn** = channel number 01 through 16

**P** = + or – for polarity relay (+ not installed, – installed)

**X** = decimal number from 0 through 9

**V** = Volts

**A** = Amperes

**S** = Sense relay

**R** = output isolation relay

### 3.4.1.8 VER (Version of Instrument Firmware)

Syntax:

**VER**

Example:

**VER**

Initiates the instrument to send the VER string.

VER initiates the Model AT8000B to assemble a string identifying the ROM firmware revision within the instrument. To actually send the string from the instrument, the Model AT8000B must be sent its talker address via the GPIB.

The returned string format is:

**VERSION: X.XX**

Where:

X.XX = the firmware version (revision) number.

### 3.4.1.9 SCR Command to Fire Crowbar

Syntax:

**SCR [CH]<channel number(s)>**

or

**SCR S**

This command turns on the SCR of the specified channel(s), programs their voltage and current to zero, but leaves all relays in whatever state they were. This condition will remain until the SCR is reset.

During the SCR on time, no crowbar or over-voltage failure will be reported.

The SCR command is used to discharge customer capacitors connected to the output of the power modules.

The SCR can be turned off or reset by any programming command, RST, or CNF. The SCR will not be turned off by query or configuration type commands such as TST, RTN, PWRL, VER, GRP, or PAR.

**CAUTION**

*The user is responsible for module damage due to over-current or current for an extended period of time. See below for the absolute maximum ratings.*

The following are the absolute maximum ratings:

Peak forward conduction current = 100 amperes

$I^2 t = 40$  ampere squared seconds from 1 to 8.3 milliseconds.

RMS current = 10 amperes. The SCR used is RCA's part number S2800 or equivalent.

#### **3.4.1.10 NOX (No Execute)**

The NOX command will delay execution of the programming string contained therein until either a GET (Group Execute Trigger) command is received or a subsequent string is received without the NOX command.

NOX is used in combination with the GET command, and it can be used to simultaneously trigger events on multiple GPIB controlled devices. The GET command is issued simultaneously to every instrument on the GPIB. Therefore, it is possible to prepare instruments to perform different tasks when activated by the GET command.

Only programming strings (strings starting with CH...) may be externally activated with the NOX command. All other strings may not contain the NOX command.

#### **3.4.1.11 GET (Group Execute Trigger)**

The GPIB defined GET command is implemented. The NOX command, when added anywhere to a programming string, delays execution of that string until either a GET command is received, or until another string is received without the NOX command in it.

The GET command is simultaneously issued to every instrument on the bus. Therefore, it is possible to prepare instruments to perform different tasks when activated by the GET command.

The user can activate specified channels to specified setting at the same time that other equipment is activated or triggered. The user can simultaneously execute multiple strings that are received at different times.

### 3.4.2 Channel Parameters

Channel parameters are the actual setup instructions for each specified channel. Everything a channel needs to know is contained therein. Those items regarding interaction between channels is more of an internal system nature and thus part of the above topic on Instrument Commands.

It is not necessary to reprogram every parameter within a channel setup. The Model AT8000B remembers its most recent setup.

Usually, only one or two parameters need to be updated, but the entire setup does not need to be re-programmed.

It is normal to program several to all channels within the same programming string. The Model AT8000B executes the entire string simultaneously, regardless of content or length. Any channel parameter, syntax, or command error rejects the entire string.

Channel parameters may not be combined with instrument software commands (the above topic) within the same programming string. Voltage and current (CURL or CURR) must be programmed within the same string or the processor will provide default values for the unspecified parameter. Note the use of <space> in the syntax.

Syntax for channel parameters requires a channel (CH) assignment followed by the parameter setup for that channel. Multiple parameters (VOLT, CURR, or CURL relays) or merely one parameter may be included in a single channel's programming string.

Should multiple channels be programmed within one GPIB string, each channel is separated by a comma (,). Individual parameters within a channel setup do not use commas nor any other separator except <space> immediately prior to each parameter.

The syntax is :

**<channel><parameter> [<parameter>...]**

or

**<channel><parameter>  
[<parameter>...] [,<channel> <parameter>[<parameter>...]**

### 3.4.2.1 CH (Channel Number)

Syntax:

**CH <channel>**

or

**CH<channel>**

Examples:

**CH 1**

Channel 1.

**CH4**

Channel 4 (note that a leading space is not required)

CH consists of one or two digits to assign a channel number from 1 to 16. A leading zero is not required. A <space> between CH and the channel number is not required. All parameter entries following in the programming string refer to this channel until canceled by a new CH assignment. A new CH assignment is required even if the same channel is desired in the next programming string.

### 3.4.2.2 VOLT (Voltage)

Syntax:

**VOLT <value>**

Examples:

**CH 6 VOLT 3.3**

Set up channel 16 for 3.3 volts.

**CH 3 VOLT 12**

Set up channel 3 for 12 volts.

**CH 2 VOLT -0352E+1**

Set up channel 2 for -3.52 volts.

VOLT is used to set the voltage. VOLT must be followed by at least one <space> and <value>. When VOLT is programmed and current (either CURL or CURR) are not specified, the default is the maximum CURL allowed for the voltage selected.

### 3.4.2.3 CURL (Current Limit)

Syntax:

**CURL <value>**

Examples:

#### **CH1 CURL 4.3**

Set up channel 1 for a current limit of 4.3 amperes.

#### **CH3 CURL .1E+2**

Set up channel 3 for a current limit of 10 amperes.

CURL sets the Current Limit in amperes. CURL must be followed by at least one <space> and <value>. CURL cancels the Constant Current (CURRE) Mode. CURL should be accompanied by a non-zero value, or else a CURL error is likely (virtually any load draws current, even the internal load). CURL must be accompanied by a VOLT setup or a syntax error is generated.

### 3.4.2.4 CURRE (Constant Current)

Syntax:

**CURRE <value>**

Example:

#### **CH1 CURRE 12**

Set up channel 1 for a constant current of 12 amperes.

CURRE sets up the Constant Current value in amperes and enters the Constant Current Mode (CURRE LED illuminated). CURRE must be followed by at least one <space> and <value>. When CURRE is programmed and a VOLT value is not specified, the default condition is the maximum compliance voltage allowed for the channel (module).



**3.4.2.5     CLS (Close)**

Syntax:

**CLS**

Example:

**CH7 CLS**

Close the output on channel 7.

**CH2 CLS, CH3 CLS**

Close the outputs on channels 2 and 3.

CLS sets the channel to close its output isolation relay, thus connecting the channel output voltage (and current) to the external load.

**3.4.2.6     OPN (Open)**

Syntax:

**OPN**

Examples:

**CH3 OPN**

Open the output on channel 3.

**CH1 OPN, CH2 OPN**

Open the outputs on channels 1 and 2.

OPN sets the channel to open its output isolation relay, thus disconnecting output power to the external load.

**3.4.2.7     SENS I (Sense Internal)**

Syntax:

**SENS I**

Example:

**CH14 SENS I**

Directs Channel 14 to use internal voltage sensing.

SENS I sets the channel to open its sense relay, thus sense voltage internally. The internal sense point is before the output relays and load regulation is approximately 20 mV per ampere.

**3.4.2.8     SENS X (Sense External)**

Syntax:

**SENS X**

Example:

**CH12 SENS X**

Directs Channel 12 to use external voltage sensing.

SENS X sets the channel to close its sense relay. Thus, the channel monitors/regulates voltage at the far end of the sense leads which are normally located at the application load. The sense relay automatically switches to internal while the output isolation relay is open. If the channel is programmed for SENS X, the sense relay automatically switches to external when the output isolation relay is closed.

### 3.4.2.9 DELAY (Time Delay)

Syntax:

**DELAY X**

Example:

**CH2 VOLT 3.3 DELAY 10**

DELAY X allows a channel to be programmed with a delay of time value 'X' relative to another channel being programmed, where 'X' is a numerical value between 1 and 255 in milliseconds.

The following command strings show the first method. These command strings are discussed in the next paragraph.

**RST 1,2,3,5**

**CH1 CLS,CH2 CLS,CH3 CLS,CH5 CLS**

**CH1 VOLT 1.5,CH2 COLT 3.3 DELAY 250,CH3 VOLT 5,CH5 VOLT 12 DELAY 252**

The above commands state that channels 1, 2, 3, and 5 are to be programmed as follows. First, reset these four channels; this sets the output voltages to zero, and opens the output relays. Then close the output relays of each of these four channels. Finally, program the channel 1 output to 1.5 volts at time zero; program the channel 2 output to 3.3 volts 250 milliseconds after time zero; program the channel 3 output to 5 volts at time zero; and program the channel 5 output to 12 volts 252 milliseconds after time zero (see Figure 3-1 below).

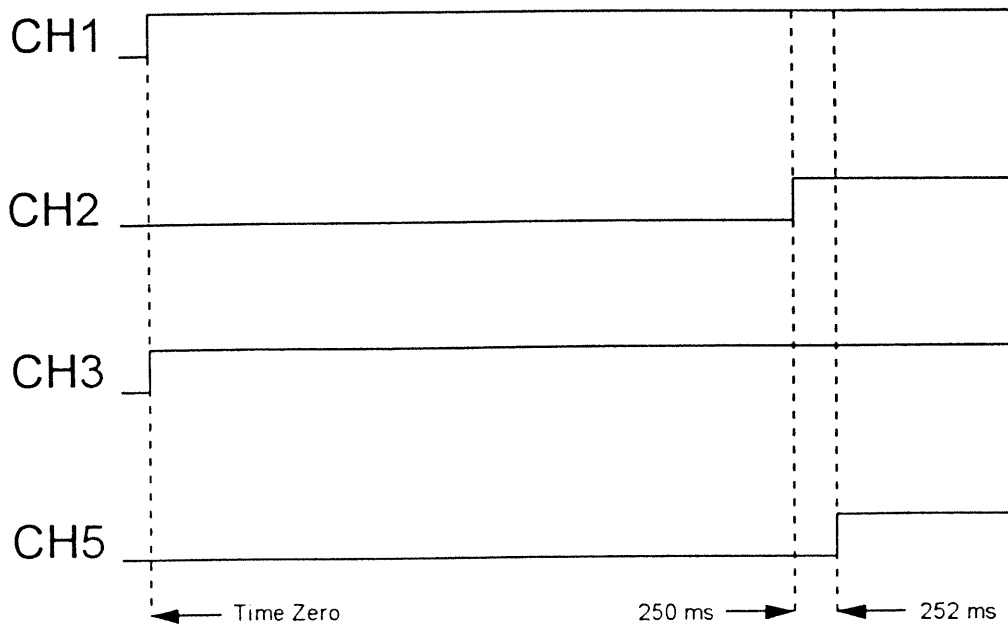

Figure 3-1. Timing Diagram of Outputs for Approach #1

Alternatively, if the gap between time zero and the 250 ms point is too small, and since the DELAY parameter accepts a maximum argument of 255 milliseconds, to get larger delays between the *effective* time zero point and activation point of the other channels, the following approach would work:

```

RST 1,2,3,5
CH1 CLS,CH2 CLS,CH3 CLS,CH5 CLS
CH1 VOLT 1.5 CH3 VOLT 5
(At this point the GPIB master shall compute a delay determined by experiment to result
in the needed delay to separate the above commands from the commands coming next;
this delay might be 200 to 400 ms or so).
CH2 VOLT 3.3 DELAY 10,CH5 VOLT 12 DELAY 11
    
```

The above command would result in a timing diagram shown in Figure 3-2 below.

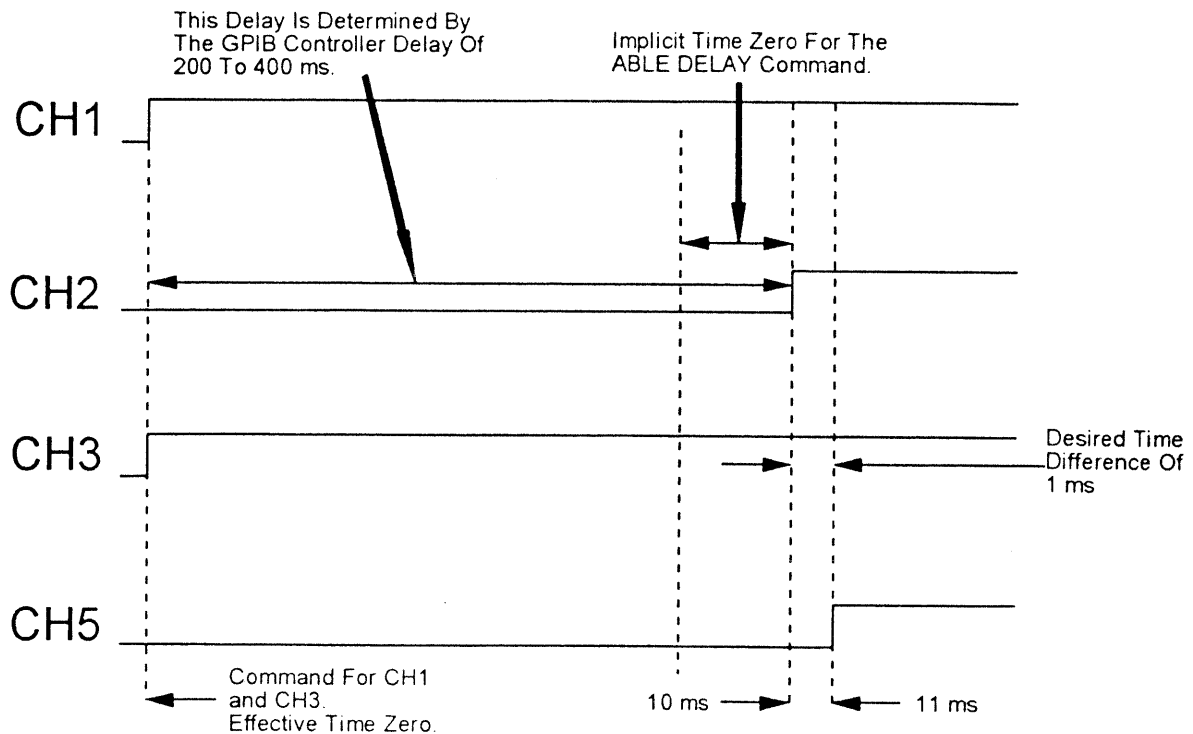

Figure 3-2. Timing Diagram of Outputs for Approach #2

A third approach, illustrated so as to generate the output timing of Figure 3-1, uses the GPIB G(roup) E(xecute) T(igger) GET command to trigger the timing.

```

RST 1,2,3,5
CH1 CLS,CH2 CLS,CH3 CLS,CH5 CLS
CH1 VOLT 1.5 NOX
CH2 VOLT 3.3 DELAY 250 NOX
CH3 VOLT 5 NOX
CH5 VOLT 12 DELAY 252 NOX

```

After the above sequence of commands, the GPIB controller must, when the GPIB controller is ready, send the GET command to cause all of the above commands suspended by the NOX (which stands for "no execute") command to execute with the specified timing. A fourth approach, if the user does not wish to use the GET command, is to instead issue the last command without the NOX keyword, thereby causing all previously suspended commands, with that last command also, to execute with the specified timing.

Limitations of the DELAY command:

Firmware paralleling with the PAR command is not supported by the DELAY command, and any attempt to use the DELAY command with a parallel channel results in a timing conflict between the rise of the slave module(s) and the master module.

Version Considerations

Version 4.75 of the AT8000B firmware restricts the use of the DELAY command to slots 1-6. Version 4.76 of the AT8000B firmware lifts this restriction, and now allows use of the DELAY command with all slots 1 to 16.

### **3.4.3 Example Message Strings With ABLE**

The following are examples of typical programming strings sent to the Model AT8000B. Recall that the entire string is processed simultaneously for concurrent changes at the individual channel outputs. Only those parameters requiring change are to be sent, thus saving programming time.

Example 1:

**CH1 VOLT 12.0 CURL 1.35 OPN, CH12 CURR .55 VOLT -.102E+2 SENS X CLS, CH9 VOLT 2.5 OPN SENS I, CH3 CLS CURR 1.12**

Channel 1 to 12.0 volts, a current limit of 1.35 amperes, the output isolation relay open, and no change to the sense relay.

Channel 12 to 0.55 amperes in the Constant Current Mode, the compliance voltage (maximum) is a negative 10.2 volts, external sense relay, and the output isolation relay is closed.

Channel 9 to 2.5 volts at the maximum available (since unspecified) current, the output isolation relay open, and internal sense.

Channel 3 to 1.12 amperes in the Constant Current Mode, the maximum compliance voltage is available (since unspecified), the output isolation relay is closed, and no change to the sense relay.

Example 2:

**CH4 CLS, CH5 CLS, CH6 CLS**

Causes the output isolation relays on channels 4, 5, and 6 to close simultaneously.

Example 3:

```
10  DIM A$[200]
20  OUTPUT 717 "RTN S"
30  ENTER 717;A$
40  DISP A$
50  END
```

The memory within the controller (DIM A\$[200]) is reserved to accept the returned string from the Model AT8000B. These characters are more than enough for several channels.

The controller outputs the command string onto the GPIB from controller port 7 (the first 7 of 717) and sends the string "RTN S" to the instrument at GPIB listen address 17 (the second part of 717). The string "RTN" initiates the Model AT8000B processor to formulate a string identifying the instrument setup parameters. The "S" tells the instrument processor that all installed channels are to be included within the formulated string.

ENTER 717 enables the instrument at GPIB address 17 (the Model AT8000B) to talk while the controller now listens. The Model AT8000B processor now sends its message string on the GPIB to whomever is listening (the controller). The controller places the incoming characters from the GPIB into a string A\$. The transfer is completed at the end of the string when the Model AT8000B sends <CR><LF>.

The controller displays the typical string A\$ onto its display as follows:

```
RTN: CH04=-12.35V 04.03A X C,
CH03=+05.00V 10.00A X C,
CH02=+5.4V 00.10C I C,
CH01=+2.8V 03.55A X C
```

### 3.4.4 Service Request Status Bytes

The Model AT8000B ABLE version sends all of its error and service request messages via the Service Request (SRQ) on the GPIB. These include programming errors, run-time failures and requests to talk to its internally formulated message string.

Application software should be written to periodically check for Service Requests (GPIB SRQ flag) after performing Confidence test and channel programming. This assures the instrument is completely functional and the programming setups are accepted.

Occasional checks during normal operation verify the presence of any run-time faults. Be sure to allow sufficient processing time (usually just a few hundred milliseconds) within the instrument, when programming channel setups and for lengthy activities such as TST and CNF. If insufficient time is allotted prior to reading the SRQ byte, the instrument processor may have not yet completed its processing. Thus, the SRQ byte is not necessarily updated in time when it is read by the controller.

The SRQ message consists of a single byte of information. In the event an old message byte has not been read, the Model AT8000B retains only the most recent one. Upon being read, the SRQ message is cleared and SRQ line is released. Serial poll activities are handled separately from normal programming strings. Each controller, and its own language subset, implements the serial poll via different commands.

Some treat the SRQ flag as a flag for occasional inspection. Others may treat the SRQ as an interrupt for immediate polling and thus immediate attention. However, each should return the SRQ status byte to the program for analysis.

Should the received status byte not correctly interpret messages as listed below, suspect that the controller (or its software driver) is not monitoring all eight data bits on the GPIB. The last three columns of Table 3-1 use the full eight data lines.

### 3.5 IEEE-488 DEFINITIONS

The Model AT8000B implements the GPIB (General Purpose Interface Bus) for all remote programming and returned messages (GPIB and IEEE-488 are completely interchangeable terms). The Model AT8000B GPIB listen address is set on the rear of the master chassis via a 5-bit DIP switch as described in Section II. Programming of all instrument channels requires only the single GPIB address.

Mnemonics are implemented and behave as defined by the IEEE-488 standard. The Model AT8000B has no special nor unusual GPIB implementation requirements. The mnemonics listed in Table 3-2 below may change name from controller to controller.



Table 3-1. Service Request Messages

<u>SRQ BYTE</u>		<u>DESCRIPTION</u>	
<u>DEC</u>	<u>HEX</u>		
73	49	Emergency Shutdown	
74	4A	Syntax error	
75	4B	Command error	
76	4C	Input buffer overflow	
77	4D	Multiple channel failures	
78	4E	Test measurement system (BIT) overflow	
79	4F	Send talk address so message may be sent	
80	50	Low AC Input Power	

<u>CHAN</u>	<u>CROWBAR</u>		<u>CURL</u>		<u>NOT INSTALL</u>		<u>CNF TEST</u>		<u>THERMAL</u>	
	<u>DEC</u>	<u>HEX</u>	<u>DEC</u>	<u>HEX</u>	<u>DEC</u>	<u>HEX</u>	<u>DEC</u>	<u>HEX</u>	<u>DEC</u>	<u>HEX</u>
1	81	51	101	65	201	C9	221	DD	240	F0
2	82	52	102	66	202	CA	222	DE	241	F1
3	83	53	103	67	203	CB	223	DF	242	F2
4	84	54	104	68	204	CC	224	E0	243	F3
5	85	55	105	69	205	CD	225	E1	244	F4
6	86	56	106	6A	206	CE	226	E2	245	F5
7	87	57	107	6B	207	CF	227	E3	246	F6
8	88	58	108	6C	208	D0	228	E4	247	F7
9	89	59	109	6D	209	D1	229	E5	248	F8
10	90	5A	110	6E	210	D2	230	E6	249	F9
11	91	5B	111	6F	211	D3	231	E7	250	FA
12	92	5C	112	70	212	D4	232	E8	251	FB
13	93	5D	113	71	213	D5	233	E9	252	FC
14	94	5E	114	72	214	D6	234	EA	253	FD
15	95	5F	115	73	215	D7	235	EB	254	FE
16	96	60	116	74	216	D8	236	EC	255	FF
MULTI			237							
BIT	218	DA	238							

MULTI = Multiple Channels      BIT = Built In Test Board

Table 3–2. GPIB/Mnemonic Listing

GPIB	Mnemonic
ATN	Attention
DAB	Data Byte
DAC	Data Accepted
DAV	Data Valid
DCL	Device Clear
IFC	Interface Clear
MLA	My Listen Address
MTA	My Talk Address
REN	Remote Enable
RFD	Ready For Data
UNL	Unlisten
UNT	Untalk

### 3.5.1 ABLE Implementation of the GPIB

ABLE technical implementation of the GPIB is:

Floating point decimal per IEEE 728–1982. Accepts signed NR1, NR2, and NR3.

Message separator:

**SR1,**

End of string:

**<CR><LF>; <CR><LF> and EOI; or EOI alone.**

The ABLE complies and conforms to IEEE 488–1978 Standard GPIB (General Purpose Interface Bus).

Implementation subsets of this standard are described in Table 3–3.

Table 3–3. ABLE Implemented Subsets on GPIB

Function	Subset	Definition
SH	SH1	Source handshake capability.
AH	AH1	Acceptor handshake capability.
T	T6	Talker (basic talker, serial poll, no talk only mode, unaddressed to talk if addressed to listen).
L	L4	Listener (basic listener, no listener only mode, unaddressed to listen if addressed to talk).
SR	SR1	Complete service request capability.
RL	RL1	Remote/local capability.
PP	PP0	No parallel poll capability.
DC	DC1	Device clear and selected device clear capability.
DT	DT0	No device trigger capability.
C	C0	No controller capability.

The Model AT8000B ABLE interface is defined as a listen and talk device with remote and local capability. Local lockout of keyboard is automatic whenever the instrument is in Remote mode (RMT LED is illuminated).

Serial poll is supported in ABLE. Both the device clear and selected device clear are implemented comparable to the remote RST command, but all channels simultaneously.

# Notes

## **SECTION IV**

# **THEORY OF OPERATION**



## 4.1 BLOCK LEVEL DIAGRAM

See Figure 4–1 for the AT8000B Block Level Diagram.

## 4.2 PROCESSOR CONTROL

See Figure 4–2 for an overview of the Chassis Mainframe System.

The processor performs a vital role in system operation and maintenance as it is involved in virtually every activity. The processor not only initializes the instrument to a safe state, but continuously runs its own internal firmware program to accept commands from the GPIB, error check input setups, flag discrepancies, direct setups to the desired channel(s), control precise timing events within channel modules including switching internal relays, delays, and more.

While operating DC power on one or more channels, the processor monitors for run-time flags from the channel module(s) should any discrepancy occur. The processor determines the exact nature of any flag and determines the course of action – even to a channel (or channels) protective shutdown. Other channels in standby (not on) undergo continuous checks by the processor to assure their digital logic and analog readiness. The built-in-test (BIT) board performs additional checks. Remotely, the operator or programmer may query the Model AT8000B for any error flag status messages.

### 4.2.1 System Operation

When power is applied to the AT8000B, the processor drives all relay drivers to the inactive state to prevent output glitches at turn-on, initializes the GPIB chip, and clears all processor memory. The routine then performs several activities to identify its own contents and ensure readiness for operation. The rear panel (backplane) GPIB address DIP switch is read. Next, all channels are quickly scanned to determine which type of module is installed in each given channel, if any, and its associated range, voltages and current capacities, etc.

Since this system includes an additional extender chassis, the power must be on prior to the master chassis power. This ensures the processor will scan and initialize the chassis. If any extender chassis is late in being powered on, the processor assumes the chassis does not exist. Use of a single AC power disconnect to both chassis will accomplish this.

The Power On routine exits into the Idle Loop routine. The Model AT8000B remains in this Idle Loop as a continuous scan for inputs and to update the instrument activity. This routine scans for flags from both active and inactive channels, supervises Test Board activity, and sends updates to the controller. The Idle Loop is momentarily interrupted only to service remote controller-initiated GPIB activity, update channel parameters, and perform the Confidence Test.



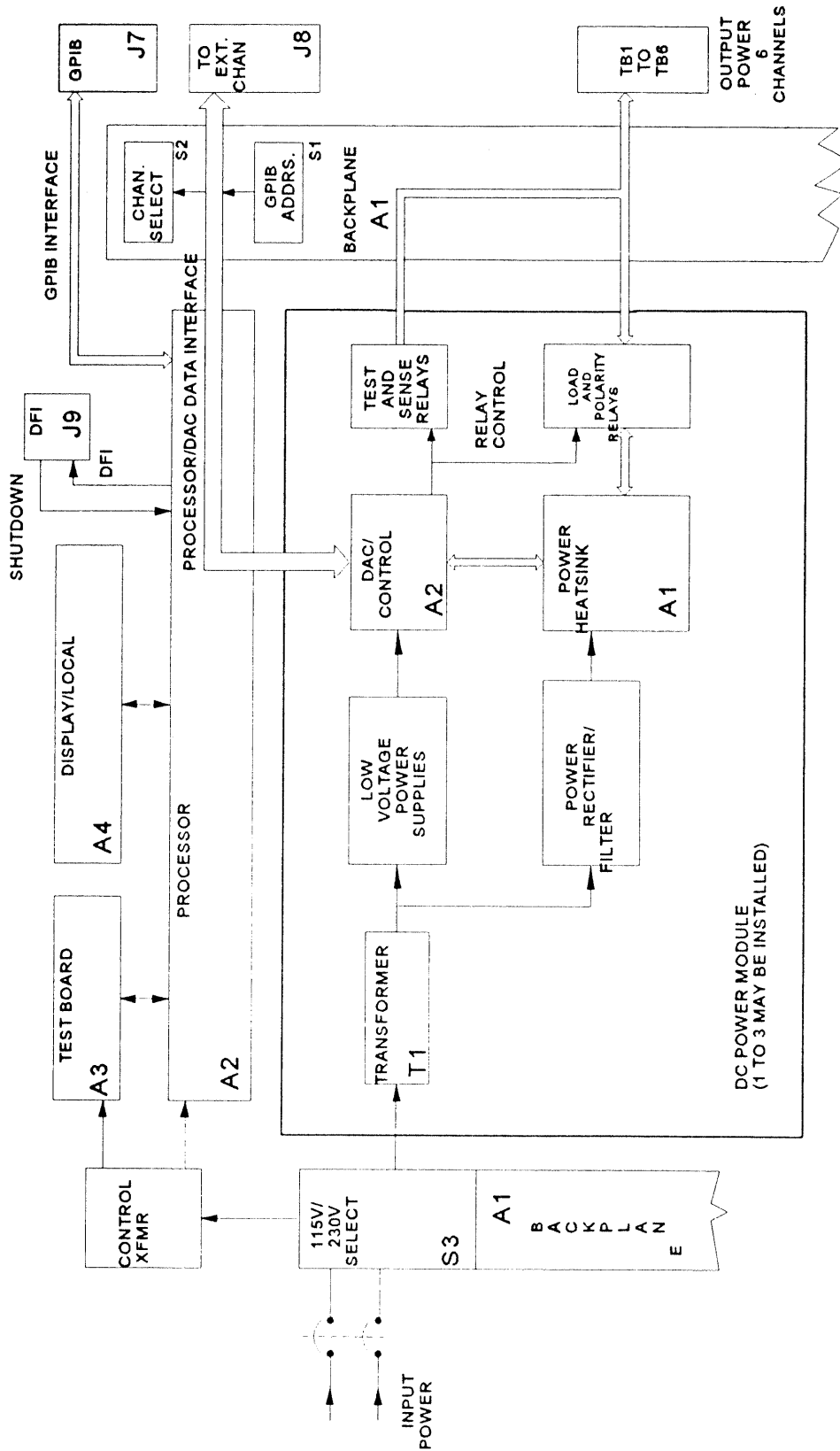

Figure 4-1. AT8000B Block Level Diagram

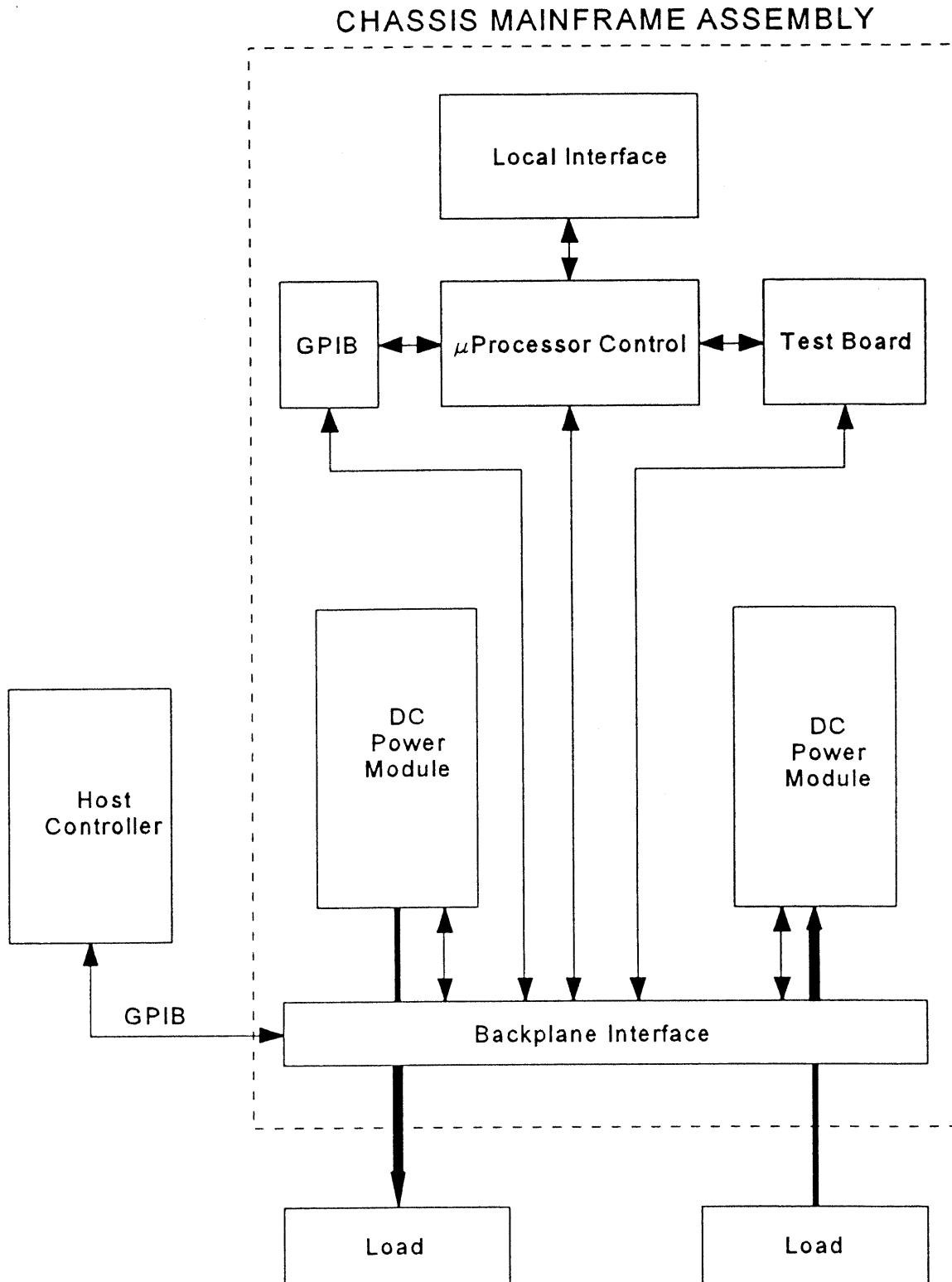

Figure 4-2. Chassis Mainframe System Functional Block Diagram

**SECTION V**

**PARTS LIST**



## 5.1 GENERAL

This section contains a listing of all part numbers used in the manufacture of the AT8000B. Parts are located on the diagrams in Section VI and correlated on the parts list by using their reference designators and/or Elgar part number.

### NOTE



*Trimming capacitors are factory selected and their replacement is considered beyond the scope of customer maintenance.*

## 5.2 SPARE PARTS ORDERING

When ordering spare parts, specify the part name, part number, manufacturer, component value and rating. If complete assemblies are desired, contact Elgar Corporation, 9250 Brown Deer Road, San Diego, CA 92121. Specify the assembly number, instrument series number and instrument name when ordering.

## 5.3 PARTS LISTS

Table 5-1 provides the Parts Lists included in this section.

Table 5-1. AT8000B Parts Lists

Number	Assembly
AT8B-06010102-4354	Final Assembly, Master Chassis – AT8000B

**Notes**

AT8B-06010102-4354 OPCODE: 3 REV: B FINAL ASSY.MSTR CHAS - AT800B

MODEL: AT8000B

ECO.No: N970583

DATE OF LAST ECO: 06/02/97

OP: ORDER POLICY CODE  
 REQ:N=PART OPTIONAL  
 Y=PART REQUIRED  
 PF: N=PART DOES NOT PRINT ON SALES ORDER  
 Y=PART PRINTS ON SALES ORDER W/O PRICE  
 P=PART PRINTS ON SALES ORDER WITH PRICE

PART NUMBER	DESCRIPTION	O	P	RV	ITEM NO.	QTY PER ASSEMBLY	YIELD FACTR	UM	SC	EP	R	QF	DEFAULT QUANTITY	DAYS OFF SET	REFERENCE DESIGNATOR	EFFECTIV DATE	OBSOLETE DATE
5691286-10	CHASSIS ASSY AT8000B	3	B		1	1.000	1.000	EA	M	YN			1.000	0		05/20/97	99/99/99
5691288-91	PWR MOD.MSTR.6V.115VAC	0	L		2	2.000	1.000	EA	M	YN			2.000	0		04/30/97	99/99/99
5691288-92	PWR MOD.MSTR.4V.115VAC-AT8000B	3	B		3	2.000	1.000	EA	M	YN			2.000	0		00/00/00	99/99/99
5691390	CONFIG SHT AT8B-06010102-4354	3	A		4	.000	1.000	EA	P	YN			.000	0	REF	00/00/00	99/99/99
9960066-01	LABEL SERIAL TAG	3	C		5	1.000	1.000	EA	B	YN			1.000	0		00/00/00	99/99/99
5691288-81	PWR MOD.MSTR 12V 115VAC	3	K		7	2.000	1.000	EA	M	YN			2.000	0		04/30/97	99/99/99
M691390-01	MANUAL.OPER & SERVICE-AT8000B	3	B		8	.000	1.000	EA	P	YN			.000	0		05/20/97	99/99/99





**SECTION VI**

**SCHEMATICS AND  
ASSEMBLY DRAWINGS**



## 6.1 GENERAL

This section contains schematic diagrams and parts layout diagrams for the AT8000B. The schematic diagrams should be used to understand the theory of operation and as an aid in troubleshooting the unit.

Components identified as "trim" or "FSV" are factory selected parts whose values are determined at the time of final checkout.

## 6.2 DIAGRAMS

Table 6-1 provides a listing of the diagrams included in this section.

**Table 6-1. AT8000B Diagram Listing**

Diagram Number	Component
5691390	Configuration Sheet, AT8B-06010102-4354

## Notes

APPLICATION		REVISIONS				
NEXT ASSY	USED ON	LTR	DESCRIPTION	DATE	APPROVED	
FINAL ASSY	AT8000B	01	PILOT RELEASE PER DRN PR1370	4-17-97	MARK LEJEUNE	
		02	REVISED PER ECN P970433	5-29-97	MARK LEJEUNE	
		03	REVISED PER ECN N970527	5-29-97	MARK LEJEUNE	

CHASSIS	5691286-10	CH	M/S	VOLTS	AMP	WATTS	L/P	P/N	VOLTS	S/N
1		1	M	4	20	80	L/P	5691288-92		
		2	M	6	16	96	L/P	5691288-91		
		3	M	12	10	120	L/P	5691288-81		
		4	M	4	20	80	L/P	5691288-92		
		5	M	6	16	96	L/P	5691288-91		
		6	M	12	10	120	L/P	5691288-81		

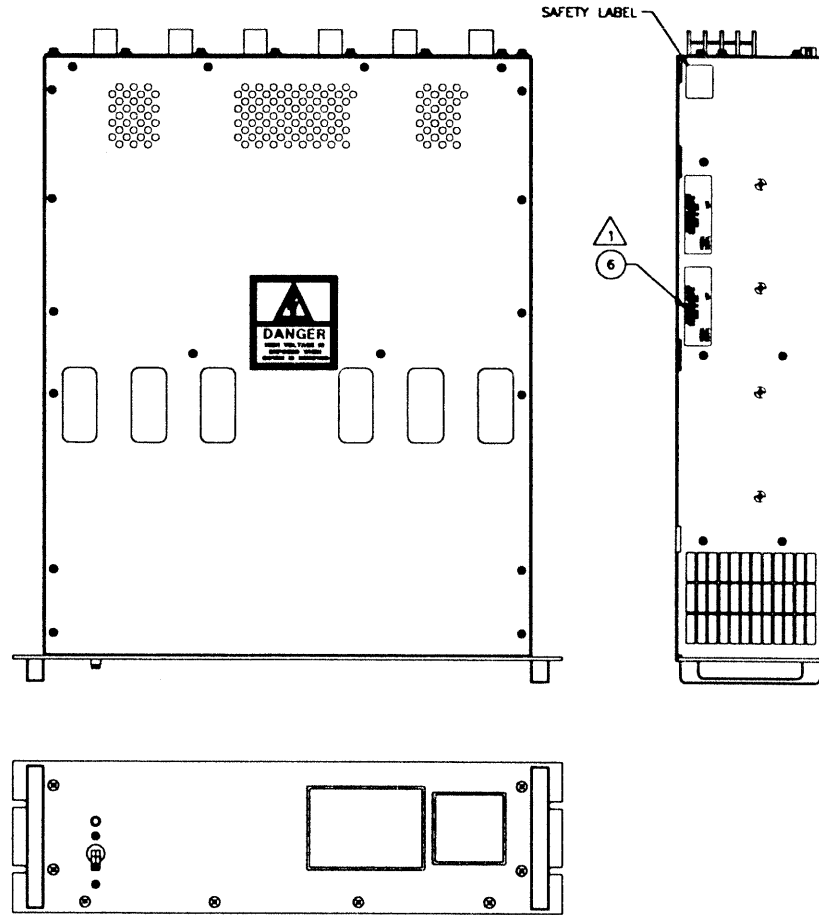

NOTE:



MARK LABEL WITH FOLLOWING INFORMATION:  
 MODEL NO: AT8B-06010102-4354 X  
 (X INDICATES REV POSITION)  
 SERIAL NO: TBD BY MFG  
 LOT NO: TBD BY MFG

CONTRACT NO.		<b>ELGAR</b>	
FIRST MADE FOR:			
APPROVAL	DATE	TITLE	
DRAWN A. A. BIGORNIA	04-17-97	CONFIGURATION SHEET	
CHECKED J. TRAYNOR	04-17-97	AT8B-06-01-01-02-4354	
ENGINEER C. SAN PEDRO	04-17-97	SIZE	CODE IDENT NO
QA-REL QUANG LE	04-17-97	A	25965
		DWG. NO.	REV
		5691390	03
SCALE NONE		SHEET 1 OF 1	



# **APPENDIX A**

## **WIRE GAUGE SELECTION**





The following guidelines assist in determining the optimum cable specification for the user's power applications. These guidelines are equally applicable to both DC and low frequency AC (up to 5 KHz) power cabling. The same engineering rules apply whether going into or out of an electrical device. Thus, this guide applies equally to the input cable and output cable for the ELGAR instrument and application loads.

Power cables must be able to safely carry maximum load current without overheating or causing insulation destruction. It is important to everyday performance to minimize IR (voltage drop) loss within the cable to a maximum of 1.5 volts total path. These losses have a direct effect on the quality (tight specifications) of power delivered to and from instruments and corresponding loads.

As a rule of thumb, specifying a generously larger power cable wire gauge has a negligible fiscal impact when compared to the costly investment in time and effort to evaluate and overcome both the cable deficiencies and the performance tradeoffs associated with a marginal (smaller) wire gauge.

When specifying wire gauge, the operating temperature needs to be considered.

Wire gauge current capability and insulation performance drops with increased temperature developed within a cable bundle and with increased environmental temperature. Thus, short cables with generously overrated gauge and insulation properties come well recommended for power source applications.

Avoid using published commercial utility wiring codes. These codes are designed for the internal wiring of homes and buildings and accommodate the safety factors of wiring loss heat, breakdown insulation, aging, etc. However, these codes consider that up to 5% voltage drop is acceptable.

Such a loss directly detracts from the quality performance specifications of the ELGAR instrument. Frequently, these codes do not consider bundles of wire within a cable arrangement.

Sense lines carry very little current and, thus, have negligible gauge overrating requirements. Sense lines tend to be particularly sensitive to induced voltages from nearby cables and from electrically noisy devices. Any disturbance induced onto sense lines is immediately signaled back to the instrument with a direct adverse effect on the output terminals.

To minimize undesired sense line pickup, sense line cables should use the canceling effects of twisted pair wires.

Shielded twisted pairs are even better, if needed. Sense lines should be physically separated from high current output, ideally via a separate cable. Sense resistors, if used, should be connected as close as practical to the load. Observe the maximum remote sense voltage drop limit (see table below).

High frequency disturbances are usually minimized by prudent use of 0.01mfd to 1.0  $\mu$ fd bypass capacitors.

In high performance applications, as in motor start up and associated inrush/ transient currents, extra consideration is required. The cable wire gauge must consider peak voltages and currents which may be up to ten times the average values. An underrated wire gauge adds losses which alter the inrush characteristics of the application and, thus, the expected performance.

The following table identifies popular ratings for DC and AC power source cable wire gauges.

**Recommended Wire Gauge Selection Guide Table**

Column 1	Column 2	Column 3	Column 4
Size (AWG)	Amperes (Maximum)	Ohms/100 Feet (One Way)	IR Drop/100 Feet* (Col. 2 X Col. 3)
18	5	0.473	2.363
16	7	0.374	2.621
14	15	0.233	3.489
12	20	0.147	2.940
10	30	0.095	2.859
8	40	0.053	2.136
6	55	0.033	1.837
4	70	0.021	1.477
2	95	0.013	1.273

\* A maximum of 0.75V is allowable.

The following notes apply to the above table and to the power cable definition:

1. The above figures are based upon insulated copper conductors at 30°C (86°F), two current carrying conductors in the cable plus a safety ground (chassis) plus a shield.

Column 2 and Column 3 in the table above refer to the "one way" ohms and IR drop of current carrying conductors (e.g., a 50-foot cable contains 100 feet of current carrying conductors).

2. Determine which wire gauge to use for the application by knowing the expected peak load current ( $I_{peak}$ ), the maximum tolerated voltage loss ( $V_{loss}$ ) within the cable, and the one way cable length. The formula below determines which ohms/100 feet entry is required from Column 3. Read the corresponding wire gauge from Column 1.

$$(\text{Column 3 value}) = V_{loss} / [I_{peak} \times 0.02 \times (\text{cable length})]$$

Where:

Column 3 value = Entry of the table above

Cable length = One way cable length in feet.

$V_{loss}$  = Maximum loss, in volts, permitted within cable.

Special case: Should the  $V_{loss}$  requirement be very loose, the peak may exceed the maximum amperes (Column 2). In this case, the correct wire gauge is selected directly from the first two columns of the table.

Example:

A 20 ampere ( $I_{peak}$ ) circuit which may have a maximum 0.5 volt drop ( $V_{loss}$ ) along its 15-foot cable (one way cable length) requires (by formula) a Column 3 resistance value of 0.083. This corresponds to wire gauge size 8 AWG.

If the cable length was 10 feet, the Column 3 value would be 0.125 and the corresponding wire gauge would be 10 AWG.

3. Aluminum wire is not recommended due to soft metal migration at the terminal which may cause long term (years) poor connections and oxidation. If used, increase the wire gauge by two sizes (e.g., specify 10 gauge aluminum instead of 14 gauge copper wire).

4. Derate the above wire gauge (use a heavier gauge) for higher environmental temperatures since conductor resistance increases with temperature.

<u>Temperature in Degrees</u>		<u>Current Capability</u>
<u>C</u>	<u>F</u>	
40	104	80%
50	122	50%

5. Derate the above wire gauge (go to a heavier gauge) for an increased number of current carrying conductors. This offsets the thermal rise of bundled conductors.

<u>Number of Conductors</u>	<u>Current Capability</u>
3 to 6	80%
Above 6	70%

6. The preferred insulation material is application dependent. Elgar's recommendation is any flame retardant, heat resistant, moisture resistant thermoplastic insulation rated to a nominal 105°C (221°F). Voltage breakdown must exceed the combined effects of:
- The rated output voltage.
  - Transient voltages induced onto the conductors from any source.
  - The differential voltage to other nearby conductors.
  - Floating or series connections of supplies/ loads.
  - Safety margins to accommodate degradations due to age, mechanical abrasion and insulation migration caused by bending and temperature.
7. Sense lines are generally 24 to 18 (more mechanical strength) gauge wire, twisted pair, shielded, and have the same insulation rating and properties as its related current carrying conductors. Sense lines are physically separated (a separate cable) from current carrying conductors to minimize undesirable pickup.

8. As frequency increases, the magnetic field of the current carrying conductors becomes more significant in terms of adverse coupling to adjacent electrical circuits. The use of twisted pairs help cancel these effects. Shielded twisted pairs are even better. Avoid close coupling with nearby cables by using separate cable runs for high power and low power cables.
  
9. The above general values and recommendations should be reviewed, modified and amended, as necessary, for each application. Cables should be marked with appropriate safety WARNING decals if hazardous voltages may be present.

## Notes

# **APPENDIX B**

## **VERIFICATION CHECKSHEET**





**CONFIGURATION AND FUNCTIONAL VERIFICATION CHECKSHEET  
ELGAR MODEL AT8000B PROGRAMMABLE DC POWER SYSTEM**

Model Number: \_\_\_\_\_ Chassis S/N: \_\_\_\_\_

Equipment Property Number: \_\_\_\_\_

Part of Equipment: \_\_\_\_\_ Location: \_\_\_\_\_

Date: \_\_\_\_\_ Inspector: \_\_\_\_\_ Dept.: \_\_\_\_\_

---

AC Input Voltage 115: \_\_\_\_\_ 230: \_\_\_\_\_

Remote Language ABLE: \_\_\_\_\_ CIIL: \_\_\_\_\_

GPIB Address \_\_\_\_\_

Group Select Switch A \_\_\_\_\_ B \_\_\_\_\_ C \_\_\_\_\_

Display/Keyboard Installed Yes \_\_\_\_\_ No \_\_\_\_\_

Built In Test (BIT) Board Installed Yes \_\_\_\_\_ No \_\_\_\_\_

Output Connectors Terminal \_\_\_\_\_ MIL-SPEC \_\_\_\_\_

CONFIDENCE TEST (CNF)

Channel Number	CNF Test	Load Relay	Max. Voltage	Prog. Voltage	Meas. Voltage	Polarity Relay	Max. Current	Current Limit	Remote Test